

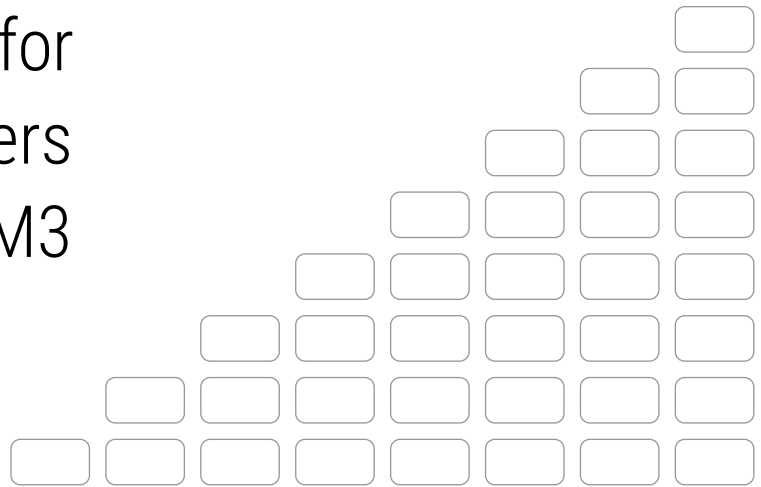

BLOCKS GUIDE

Complete Reference for
Blocks and Parameters
on the Axe-Fx III & FM3



VERSION 1.0.2 - JUNE 2020

AXE-FX III

FM3

Inside Front Cover

TABLE OF CONTENTS

Product Comparison	3	The Parametric EQ Block	60
Input & Output Blocks	4	The Phaser Block	61
Common Mix/Level Parameters	7	The Pitch Block	63
The Amp Block	9	The Plex Delay Block	74
The Cab Block	19	The Realtime Analyzer Block	77
The Chorus Block	23	The Resonator Block	78
The Compressor Block	25	The Reverb Block	79
The Crossover Block	28	The Ring Modulator Block	82
The Delay Block	29	The Rotary Block	83
The Drive Block	35	The Scene MIDI Block	84
The Enhancer Block	38	The Send Block	85
The Filter Block	39	The Return Block	85
The Flanger Block	40	The Synth Block	87
The Formant Block	43	The Ten-Tap Delay	88
The Gate/Expander Block	44	The Tone Match Block	90
The Graphic EQ Block	45	The Tremolo/Panner Block	91
The IR Player Block	46	The Vocoder Block	92
The Looper Block	47	The Volume/Pan Block	93
The Megatap Block	49	The Wahwah Block	94
The Mixer Block	51	LFO Waveforms & Phase	95
The Multiband Compressor Block	52	Tempo Cross Reference	96
The Multiplexer Block	53	Getting Help	97
The Multitap Delay Block	54		

Legal Notices

Fractal Audio Systems Blocks Guide. Contents Copyright © 2020. All Rights Reserved.

No part of this publication may be reproduced in any form without the express written permission of Fractal Audio Systems.

Fractal Audio, the Fractal Audio Systems logo, Axe-Fx, FM3, Humbuster, UltraRes, FASLINK are trademarks of Fractal Audio Systems. Manufacturer names and product names mentioned herein are trademarks or registered trademarks of their respective owners, which are in no way associated with or affiliated with Fractal Audio Systems, LLC. The names are used only to illustrate sonic and performance characteristics.

INTRODUCTION

The Fractal Audio Systems products covered by this guide have in common the use of **presets** assembled from **blocks**. Each block represents a piece of traditional equipment like an amp, speaker cab, wah pedal, or reverb unit, or an effect like a compressor, plex delay, or tone match. These blocks are placed into a **layout grid** and wired up with virtual cables to build presets. By combining different blocks you can build an entire virtual rig.

Blocks are fully programmable. A virtual drive pedal, for instance, has the same “knobs” and controls you might find on the original – and more, since Fractal Audio products are not constrained by the same limits as analog circuitry. The **Edit menu** for every block contains one or more **pages** of **parameters** to control sound functions. This comprehensive guide lists and explains the parameters for each of the different types of blocks, as well as providing an overview for each.

Differences between the Axe-Fx and FM3 are detailed in a table on the next page. The flagship Axe-Fx III has more block types and more block instances, and cases where it has an edge are highlighted in green. Some blocks are completely unavailable on the FM3 (pink highlight) while others have fewer features or parameters as noted elsewhere in this guide.

UPDATES

This guide is updated regularly as new firmware brings changes and new features. Sometimes, features added to the Axe-Fx III will be updated here prior to those changes being made in the FM3. In cases where the products diverge, this will be noted.

PRODUCT COMPARISON

Block	Description	Types	Channels	Axe-Fx III	FM3	
AMP	Amp	Here it is! 260+ amp models in one block!	269+	4	2	1
CAB	Cab	Speaker cab simulation with Factory, Legacy, and User banks to choose from.	2237	4	2	1
CHO	Chorus	Create classic mono and stereo modulation effects including vibrato.	14	4	2	2
CMP	Compressor	Control dynamics and add sustain.	7	4	2	2
XVR	Crossover	Split a signal into high and low frequency components.	1	2	2	0
DLY	Delay	Up to 8000 ms of delay, with types for analog, digital, tape, and more.	18	4	4	2
DRV	Drive	Type including boost, overdrive, distortion, fuzz, and many, many more.	43+	4	4	2
ENH	Enhancer	Classic and modern modes to create and control spatialization.	3	4	2	2
FLT	Filter	Includes low pass, high pass, band pass, and many other types.	14	4	4	4
FLG	Flanger	Various types cover everything from subtle modulation to extreme jet.	15	4	2	2
FOR	Formant	Create dynamic vowel sounds with this multi-mode formant filter.	1	4	2	2
GTE	Gate/Expander	Useful for everything from subtle control to extreme effects.	1	4	4	2
GEQ	Graphic EQ	A variety of modes allow easy, flexible tone sculpting.	15	4	4	2
IN	Input	Injects the signal from physical inputs onto the grid.	1	4	5	2
IRP	IR Player	No bells or whistles, this simple block processes a cab or other impulse.	1	4	2	0
LPR	Looper	A powerful looper with great remote control options.	1	1	1	1
MGT	Megatap	This 40-tap delay creates fantastic sonic patterns.	1	2	2	1
MIX	Mixer	Allows you to mix up to six stereo signals.	1	4	4	4
MTD	Multi-Delay	A variety of special delays including diffuser, quad-tap, and more.	6	4	2	1
MBC	Multiband Comp	Three-band compressor that is great for mastering or dynamic EQ.	1	4	2	1
MUX	Multiplexer	This input selector routes one of many inputs to an output.	1	6 ¹	2	2
OUT	Output	Transmits signal to the corresponding physical output jacks.	1	4	4	2
PEQ	Parametric EQ	The 5-band parametric equalizer allows precise control of tone.	1	4	4	2
PHA	Phaser	A variety of vintage and cutting edge phaser effects, including 'vibe.	16	4	2	2
PIT	Pitch Shift	Includes detune, harmonizer (intelligent/custom), whammy, and more.	15	4	2	1
PLX	Plex Delay	Up to eight delay lines interacting in a matrix. Gorgeous!	5	4	2	1
RES	Resonator	Resonant comb filters in parallel. Create chords and more.	1	2	2	2
RTN	Return	Receives signal from the Feedback Send block.	1	1	2	2
REV	Reverb	World-class recreations of vintage springs, rooms, halls, and more.	51	4	2	1
RNG	Ring Mod	The extremely flexible ring modulator provides for a range of cool effects.	1	2	1	1
ROT	Rotary	Simulates a classic rotary speaker with multiple microphones.	1	4	2	2
RTA	RTA	Visually plots the frequency spectrum of an input signal.	1	1	1	0
MIDI	Scene MIDI	The Scene MIDI block transmits MIDI messages whenever a Scene loads.	1	1	1	1
SND	Send	Transmits signal to the Feedback Return block.	1	1	2	2
SYN	Synth	A 3-voice monophonic synth that tracks what you play.	1	4	2	1
TTD	Ten-Tap Delay	Set the time, pan, and spacing of one to ten separate echoes.	2	4	2	1
TMA	Tone Match	Matches the Axe-Fx to the sound of an amp, recording, or device.	1	1	1	0
TRM	Tremolo	Creates classic trem, plus auto-pan or extreme psycho acoustic effects.	4	4	2	2
VOC	Vocoder	Digital re-creation of the analog classic. "Stop the human. Stop the intruder."	1	1	1	0
VOL	Volume/Pan	Simple volume block also offers channel input/output tools.	1	4	4	2
WAH	Wah	The essential wah, with multiple types based on classic originals.	8	4	2	2

¹ Multiplexer has 4 channels on the FM3.

INPUT & OUTPUT BLOCKS

IN

OUT

INPUT BLOCKS 1-4

Input blocks place signals on the grid. To process any input signal, a preset *must* have at least one Input block

Like all input meters, Input blocks are BLUE.

Each of the four numbered Input blocks inserts signal on the grid from the corresponding input:

The **Input 1** block uses the signal from Input 1.¹

The **Input 2** block uses the signal from Input 2.

The **Input 3** block uses the signal from Input 3. (Axe-Fx III only)

The **Input 4** block uses the signal from Input 4. (Axe-Fx III only)

¹ This may sound obvious at first, but unlike other inputs, Input 1 is not hard-wired to a physical jack, and may in fact be set to use your choice of different signals:
 1) **ANALOG** (the Input 1/Instrument jack), 2) **USB** on a connected computer, or 3) The Digital **SPDIF or AES** input signal if you're using Axe-Fx III.
 To select the source for Input 1, use **Input 1 Select** on the **Audio** page of the **I/O** menu under **SETUP**.

INPUT USB (AXE-FX III ONLY)

The **Input USB** block is fed signal from the **USB Outputs 7+8** ports of a connected computer. There are many creative applications for the Input USB block such as creating "hardware plugin" chains via USB, or processing backing tracks and live guitar through "mastering" effects. See your **Owner's Manual** for more on USB Audio.

Noise Gate Parameters

Every Input block includes a noise gate. All signal that appears at the block is processed by the gate, whether analog, digital, or USB.

Gate Type – The "CLASSIC" type simply opens and closes like a typical gate pedal. The "INTELLIGENT" and "NOISE REDUCER" types uses smart filtering to make the gating effect less obvious, improve note attack, and filter EMI to reduce hum and buzz. For best results, set **AC Line Frequency** in the Global menu under **Settings** to match the actual line frequency of in your region (i.e., "60 Hz" for USA/Canada/most of South America, or "50 Hz" for Europe/Australia/most of Asia, etc.).

Threshold – This determines how quiet the signal must be for the gate to close. The threshold can also be adjusted (or disabled) globally using the global **Noisegate Offset** parameter (See your Owner's Manual).

Ratio – This determines how much quieter the signal will be when the gate is closed. Think of Ratio as the lower number in a fraction expressing the output in dB. A ratio of "4" means you multiply the input in dB by 1/4 to find the output in dB. At lower ratio settings, noise is slightly reduced. At higher ratio settings, it is effectively silenced. A ratio of "1.00" would result in the gate having no effect.

Attack – determines how long it takes for the gate to open after signal levels exceed the threshold. You'll typically want this set low so the attack of your first notes can punch through naturally.

Release – determines how long it takes for the gate to close. Use a slow setting for a gradual decay to prevent your notes from being clipped suddenly or a fast setting for "djenty" clamping.

Output Level – Controls level at the output of the noise gate. This can be used to boost the overall preset input level which is useful, for example, when you really want to "smack" a Compressor or a Drive.

BYPASSING INPUT BLOCKS

Input blocks have a **Bypass** switch. When bypassed, they behave exactly like a Shunt. That is to say, their **Bypass Mode** is permanently set to "THRU". While an Input block is NOT bypassed, it *discards* signal at its grid input.

OUTPUT BLOCKS 1-4

Output blocks carry signal from the grid to various outputs. To output any signal, a preset *must* have at least one Output block.

Like all output meters, Output blocks are GREEN.

The **Output 1** block transmits signal to the physical Output 1 jacks¹ and to USB Inputs 1+2 on a connected computer.

The **Output 2** block transmits signal to the physical Output 2 jacks² and to USB Inputs 3+4 on a connected computer.

The **Output 3** block transmits signal to the physical Output 3 jacks³.

The **Output 4** block transmits signal to the physical Output 4 jacks³.

³ Axe-Fx III, Output 3 or 4 and FM3 Output 2 be set globally to echo signal from **Input 1**, though placing the corresponding Output blocks on the grid overrides this.

Output Mixer Parameters

Every Output block includes a multi-channel mixer. The channels correspond to the rows of the grid. A **Main** level controls the master mix. Each channel and Main also have **Balance** controls.

The following example demonstrates how this works (Axe-Fx III is shown). Six rows are fed into the Output 1 block, The six **Level** and six **Balance** parameters determine how signal from each row is outputted.

Grid



Output 1 Block Mixer Parameters

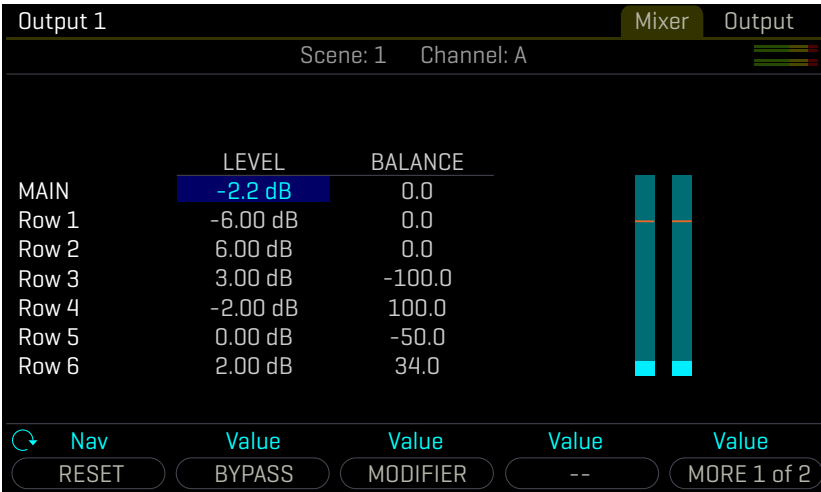

	LEVEL	BALANCE
MAIN	-2.2 dB	0.0
Row 1	-6.00 dB	0.0
Row 2	6.00 dB	0.0
Row 3	3.00 dB	-100.0
Row 4	-2.00 dB	100.0
Row 5	0.00 dB	-50.0
Row 6	2.00 dB	34.0

Above, six blocks are shown in six rows, with an Output block in the next column. It does not matter which row the Output block is in; the different channels of its mixer always correspond to the different rows of the grid. Those rows might contain blocks, shunts, or nothing.

- The Main output of the block is set to -2.2 dB. It's Balance is dead center (0.0).
- Row 1 (the Filter) will reach Output 1 at Level -6.00 dB, with Balance centered (0.0).
- Row 2 (the PEQ) will reach Output 1 at Level +6.00 dB with Balance centered (0.0).
- Row 3 (the Compressor) will reach Output 1 at Level +3.00 dB with Balance fully left (-100.0).
- Row 4 (the Synth) will reach Output 1 at Level -2.00 dB with Balance fully right (+100.0).
- Row 5 (the Delay) will reach Output 1 at Level ±0.00 dB with Balance 50.0% left (-50.0%).
- Row 6 (the Reverb) will reach Output 1 at Level +2.00 dB with Balance 34% right (+34.0).

BYPASSING OUTPUT BLOCKS

Output blocks have a **Bypass** switch. When an Output block is bypassed, it mutes the signal at the corresponding output AND on the grid. In other words, its **Bypass Mode** is permanently set to “MUTE”.

INPUT & OUTPUT BLOCK CHANNELS

Input blocks and Output blocks each have four channels. This gives them multiple sets of parameters you can use to vary their operation from scene to scene.

OUTPUT BLOCK SCENE LEVELS

Every output block is equipped with eight **Scene Level** parameters. Use these to cut or boost output for any scene. See your **Owner’s Manual** on Scenes for more information.

INPUT & OUTPUT BLOCKS AS SEND & RETURN LOOP

The “FX Loop” block found on previous products no longer exists. Instead, individual Input and Output blocks must be placed separately on the grid. In the example below, signal flows (in red) from the Output block to outboard gear and back through the Input block. The Input block serves as a “master bypass” control for the send/return loop. The Output block on the grid is connected with a cable to the Input block as shown below, but the Input block ignores grid input signals when it is engaged (left image) and ignores external input signals when it is bypassed (right image).



INPUT 1/INSTRUMENT IMPEDANCE (AXE-FX III ONLY)

The **Input Instrument Impedance** parameter appears on the **Input 1** block. This parameter changes the actual analog circuitry of the INSTR input jack to interact differently with your guitar pickups. This recreates the way that some classic effects (e.g. ‘Vibe) “load down” the pickups, causing a change in frequency response. In “AUTO” mode, the impedance is set automatically, based on the first active effect to follow the input. Normally the setting of “AUTO” is best, but you may also select any of the following values. This setting is saved with the channel.

- 1M Ω
- 1M Ω + Capacitor
- 230k Ω
- 230 k Ω + Capacitor
- 90 k Ω
- 90 k Ω + Capacitor
- 70 k Ω
- 70 k Ω + Capacitor
- 32 k Ω
- 32 k Ω + Capacitor
- 22 k Ω
- 22 k Ω + Capacitor

COMMON MIX/LEVEL PARAMETERS

Almost every block has a **Mix** page with parameters that determine how that block contributes to the preset. All **Mix** pages use one or more of the following standard parameters. Different blocks have different **Mix** page parameters because they require different approaches. You may need to change more than one parameter setting to achieve a desired result.

Mix – Determines the balance of wet and dry signals. In most cases, setting the mix by ear is best.

With the exception of a few blocks that use a constant power algorithm, Mix controls the dB levels of wet and dry signals in an inverse linear relationship. A mix setting of 50% results in both wet and dry being at -6 db in comparison to their maximum output levels. A diagram (right) illustrates this "mix law". Note: See "The Delay Block" for details on how its Mix control works differently.

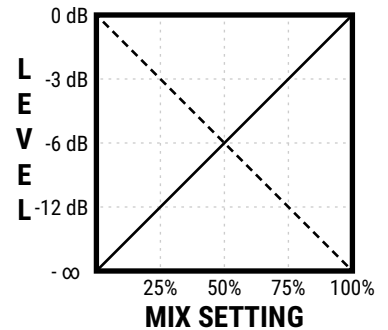

Level – As you would expect, this controls the overall output level of the block.

Balance – Every block outputs both left and right signals. As you adjust to the left or right, the opposite channel gets quieter. Both the wet and the dry are affected.

Bypass – Blocks have a dedicated Bypass parameter for the purpose of allowing Modifier control.

Bypass Mode – This setting determines what happens when the block is bypassed. The different options are detailed below. Not every option is available in every block.

MUTE – When the block is bypassed, both wet and dry are totally silenced.

THRU – When bypassed, the block is completely disengaged. None of its parameters have any effect on the sound; it behaves exactly as if it were a shunt.

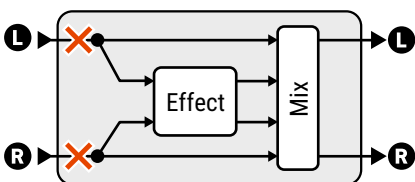

MUTE IN – When the block is bypassed, its inputs are muted. This silences both wet and dry but allows effect tails to ring out or spillover. Use this for time-based effects in parallel.

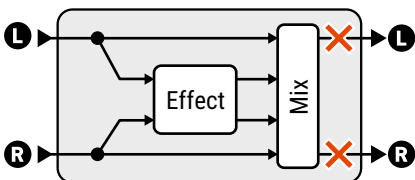

MUTE OUT – When the block is bypassed, all audio is totally silenced at the outputs. Effect tails are silenced immediately, but the input is still "listening" so tails may be heard when you engage the effect.

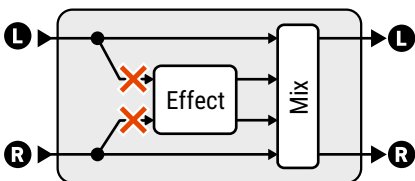

MUTE FX IN – When the block is bypassed, the inputs to the effect are muted, and the dry level is unaffected. This allows effect "tails" to ring. LEVEL and BALANCE (and even MIX) affect the dry even when the block is bypassed. Use this for time-based effects in series when you want spillover.

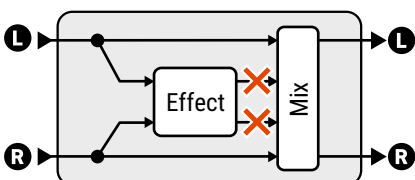

MUTE FX OUT – When the block is bypassed, the outputs of the effect are muted, and the dry level is unaffected. The effect is always "listening" so tails are heard already when you engage, but are silenced when you bypass. LEVEL and BALANCE affect the dry even when the block is bypassed.

FRACTAL AUDIO BLOCKS GUIDE

Input Select – Determines how an incoming stereo signal will be processed by an effect. You can input only “LEFT” or “RIGHT” channels, or sum “L+R” (the default setting). Input Select appears on the following blocks: Megatap Delay, Multitap Delay, Plex Delay, Reverb and Rotary.

Input Gain – Determines the amount of signal fed to the effect processor *within* the block. This simulates the way an AUX Send would normally feed an effect routed in parallel. It has no effect on the dry signal. It appears on the following blocks: Delay, Megatap Delay, Multitap Delay, Ten-Tap Delay, Pitch, Plex Delay, Resonator, Reverb.

Global Mix – This switch determines whether or not the **Mix** setting of the selected effect will be subject to an offset ($\pm 50\%$) applied using the global **Effects Mix** parameter found in the **SETUP: Global** menu.

This feature is provided so you can design presets with the built-in ability for fast mix compensation in playing environments that require more or less wet mix. It is offered on the following effect blocks: Chorus, Delay, Flanger, Megatap Delay, Multitap Delay, Phaser, Pitch, Plex Delay, Resonator, Reverb, Synth, Ten-Tap Delay, Vocoder.

THE AMP BLOCK

AMP

The Amp block reproduces the sounds of an impressive array of vintage and modern guitar and bass amplifiers, with 260+ different “types” based on stock, custom, and hybrid models. It uses our newest “Ares” Amp Modeling technology with component-level physical modeling which produces tone of a depth and quality that cannot be obtained using lesser modeling methods. Our amp models are the result of thousands of hours of incredibly detailed analysis of the actual amps that inspired them. Like “Quantum” Amp Modeling before it, Ares models the preamp tubes, tonestack, cathode follower, power supply, power amp, phase inverter, amp/speaker interaction, and more.

The Amp Block works hand-in-hand with the equally important Cab block. To learn about how amp and cab work together, try different amps through the same cab, or different cabs with the same amp. In other rig designs, the amp block is used with real guitar speakers and a power amp. In any configuration, the results are amazing: tight bass, powerful midrange, silky highs, and highly expressive touch sensitivity.

You can get great tone from these models using just the basic controls on the Type and Tone pages. Should you desire to dig deeper, you’ll find many exciting parameters that allow you to tweak and adjust the most intricate aspects of amp tone. Don’t become paralyzed by the options. The default settings are very accurate, and more than sufficient to achieve great results. An easy way to start branching out might be with Post EQ and Pre EQ. For dynamics, try Speaker Compression and Output Compression. To learn more, tap into the Fractal Audio community, and watch for [“Tech Notes” on the Fractal Audio forum](#) for tips. Above all, use your ears: rules are made to be broken; you have the tools here to create the future of tone.

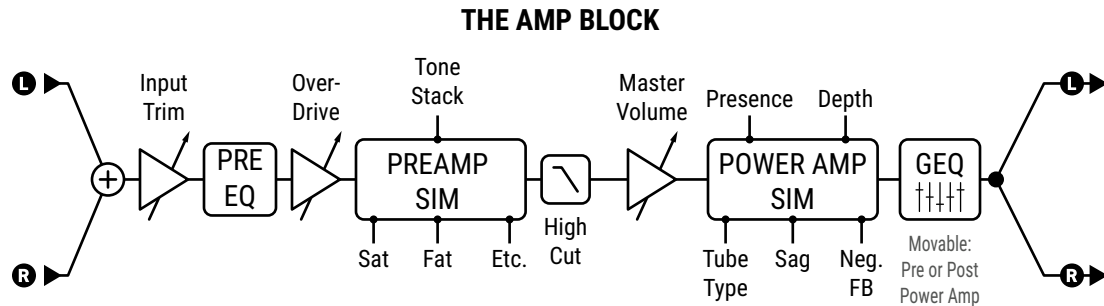

TYPE PAGE

Amp Type – Amp types are presented in an alphabetical list. Make a selection using the **VALUE** knob or **NAV** buttons. You do not need to press **ENTER**. There are over 260 different types mostly based on real-world amps. If you’re unfamiliar with the models, the Fractal Audio wiki (a publicly managed document) contains many pages of useful information, especially [“Yek’s Guide to the Fractal Audio Amp Models”](#).



As you change the amp type, you will notice that various other parameters change to different “starting values” for each type. This is perfectly normal and it helps ensure that a model sounds correct when selected. For example, if an original amp has no Master Volume control, meaning its power amp is “wide open”, the model will set Master to “10.0” to ensure accuracy. (Of course, you can still adjust any parameter as desired from the recommended starting point.)

When you press the RESET button (Push-knob A) to initialize the current Channel, the amp type is not changed but all other parameters return to default values. You can also “soft reset” an amp by changing type to another model and then back. This leaves some custom settings intact, like tone knob positions.

📁 TONE PAGE



*Note: The Tone Page can show some or all of the following parameters, based on the setting for **Tone Control Display** on the Config page of the Global menu under Setup. See your **Owner's Manual**.*

Input Drive – (aka “Drive”) sets the amount of preamp gain/distortion. Used in conjunction with the Master Volume, Input Drive determines whether the sound will be clean, broken up, overdriven, or fully distorted.

A treble peaker circuit found on the drive or volume control on many amps is also modeled. This can be heard as the low frequencies are attenuated more than the highs when the drive is turned down (and vice versa). For amps that have no Master Volume, Input Drive functions as the amp’s volume control.

Bass, Mid, Treble – Adjust these as you would the controls on any amp.

While other modelers use simple filters to approximate amp tone controls, our products recreate the exact frequency and phase response characteristics of a classic passive tonestack. In most cases, knob positions can even be matched to settings on the original amps. (Though recognize that many types of amps were built inconsistently with different types of potentiometers from one run to another.)

Many models provide tone controls NOT offered on the original amp. For example, many amps have no Mid control. To faithfully simulate such amps, set controls they are missing to “noon” (or “0” if you are using the “ACTIVE” Tonestack Type). Of course, you may still adjust these “bonus” controls to achieve innovative tones.

Please note that extreme tone and high gain settings can cause pickup squealing or excessive noise. This is especially true with **Tonestack Type** set to “ACTIVE.”

Bright Switch – Many amplifiers contain a “treble peaker,” included as a pull or toggle switch, or even hard-wired. Each amp type includes this control (even if the original mode does not). The effect may be subtle or quite pronounced depending on the amp type. This is also affected by the **Bright Cap** setting. If the original amp had no bright circuit, Bright is OFF by default but can still be turned on to apply circuit values suited to an amp of that general type. If the amp has a hard-wired treble peaker, the default state is ON.

Input Trim – Amps without an **Overdrive** control (below) will display **Input Trim** instead. This allows you to adjust for more or less preamp gain than the actual circuit being modeled. This is different from the **Input Drive** in that it does NOT interact with the surrounding circuitry to change frequency response as it is varied. In short, use Input Trim to adjust gain *without* also changing tone.

Overdrive – Amps with **Overdrive** will not display **Input Trim** (above). Adjusts overdrive. Note that Input Drive and Overdrive are applied to the appropriate points in the circuit for the amp being modeled, i.e. prior to the last triode stage or prior to the third triode.

Presence/Hi-Cut – Boosts (or cuts) the upper frequencies from the virtual power amp by varying the negative feedback frequency response. Increased presence can help a sound cut through. Note that settings for Presence don’t necessarily correspond to knob positions on the amp being modeled.

Amps with no negative feedback circuits in their design cannot utilize a realistic presence control. Therefore, if **Negative Feedback** is set (manually or automatically) to “0”, Presence becomes a high-shelf EQ at the output of the power amp, and its label changes to **Hi-Cut**. This allows you to control power amp highs even for amp models that wouldn’t normally have this capability. When changing to a model with no negative feedback (i.e. Class-A, etc.), be sure to check your Hi-Cut settings as values higher than zero will darken the sound.

Depth – Boosts low frequencies from the virtual power amp by varying the negative feedback frequency response. It is set by default to an appropriate value when the amp type is selected, but this setting may be overridden.



*Note: Presence and depth are disabled when Power Amp Modeling is turned off. For more on disabling Power Amp Modeling, see Supply Sag ([p. 12](#)) and your **Owner's Manual**.*

Master Volume – The almighty Master Volume is a very important control. It determines the distortion and dynamics characteristics of the power amp simulator, and its setting at any moment can dramatically change the amp’s sound. As it is turned up, the tone controls will have less influence, and the sound will have more “bloom” and touch sensitivity. Settings for Master don’t necessarily correspond to knob positions on the amp being modeled. With a little experimentation, you will learn to dial in different great sounding Input Drive and Master combinations.

When you select an amp type, the Master will change to an appropriate/typical setting for that amp. If a real amp doesn’t have a Master, the “correct” setting will be applied—i.e. “10”, or “wide open.”

- At high settings, less Input Drive is usually required, especially for high-gain types.
- Amps designed for preamp distortion will typically sound great with the Master set low to prevent the tone becoming muddy or noisy. This includes the “USA Lead” types and others.
- Amps with negative feedback tend to have “crunchier” power amp distortion, which can get “raspy” when driven too hard. Experiment with the interactivity of Negative Feedback and Master on distortion tone.
- With Power Amp Modeling disabled, either globally or in one specific block, Master Volume becomes a simple level control with 40 dB of range. For more on disabling Power Amp Modeling, see Supply Sag ([p. 12](#)) and your **Owner’s Manual**.
- If more power amp gain is desired, **Master Volume Trim** in the Advanced menu can be used

Input Boost, Boost Type, Boost Level – The acts as a “clean boost,” replicating the common technique of driving an amp harder by using a drive pedal with the “Drive” knob at 0 and the “Level” turned up. To use the boost, turn the switch on, choose the boost type (types are based on real pedals, each with its own EQ/color) and set the Boost Level as desired. The Boost switch can be operated with a Modifier. These controls provide a way to give an amp model more gain without the CPU overhead of adding a drive block.

Fat Switch – Emphasizes midrange and adds “body” by shifting the tonestack center frequency.

Cut Switch – Reduces the amount of low frequencies coming into the amp simulation. This can be used to achieve a “tighter” tone or to reduce low-end “flub”.

Saturation Switch – This engages a popular mod between the preamp and the tonestack for a thicker, more aggressive distortion character. The “ON (AUTH)” and “ON (IDEAL)” settings differ only in volume. “IDEAL” gives you the hotter output you wish a real amp had with saturation engaged. ;-)

Saturation Drive – Controls the amount of saturation (see above). The default value differs for each model.

Preamp Tube Type – Changes the characteristics of the virtual preamp tubes, based on real world examples.

Cathode Follower Compression – Sets the amount of compression in the virtual cathode follower. This interacts with other parameters listed in the Cathode Follower section of the Advanced page (Time, Ratio, etc.)

Preamp Bias – Sets the bias point of the last triode (not counting the cathode follower). Depending on the bias points of the previous stages, increasing or decreasing this value can alter both harmonic content and attack characteristics. Typically, if the previous stage has a negative bias then increasing this value will be more noticeable (and vice-versa).

Bright Cap – Sets the value of a virtual capacitor to determine the sonic effect of the **Bright** switch. Increasing this will make the preamp brighter and vice versa.

High Treble – Think of this as an extra tone control, useful to add “zing” or tame harsh highs.

POWER AMP PAGE

Power Tube Type – Changes the characteristics of the virtual amp power tubes. The virtual power amp includes modeling of the plate impedance of the power tubes. Plate characteristics are adjustable via **Dynamic Damping**, an advanced parameter. The Tube Type parameter allows you to select from common power tube types: 6AQ5, 6L6/5881, 6V6, 300B (triode), 6550, 6973, EL34/6CA7, EL84/6BQ5, KT66, KT77, KT88, 5881 and 6L6GB.

Power Tube Grid Bias – Sets the bias point of the virtual power amp. Lower values approach pure Class-B operation. Higher values approach pure Class-A operation.

Negative Feedback – This controls the amount of negative feedback, or damping, in the power amp simulation. Higher values give a tighter and brighter sound but can sound harsh at very high master volume levels. Lower values give a loose and gritty sound and feel. Like many other power amp parameters, Negative Feedback is set to an appropriate value whenever you change the amp type, but it can be changed as desired. For example, you might dial in some negative feedback on a “Top Boost” amp type to give the power amp a more “American” sound while still retaining the preamp voicing.

Transformer Matching – Transformer Matching is an extremely powerful parameter. Lower values cause power tubes to clip later and therefore the phase inverter and grid clipping becomes more predominant. At higher settings, power tubes clip sooner and the **Resonance** settings on the Speaker page become more pronounced. For optimum results bring up the **Master** until the desired amount of power amp distortion is achieved, then adjust **Matching** until the character of the distortion is as desired. The various **LF and HF Resonance** parameters interact strongly with this parameter, so be sure to experiment with those as well when crafting a tone.

Bias Excursion – The higher the value, the more the bias shifts when the virtual power tubes are overdriven. Bias excursion pushes a power amp from Class-AB operation towards Class-B operation, which can result in crossover distortion. A little goes a long way, but too much can lead to what is referred to as “blocking distortion” which can make an amp sound unpleasant.

Power Tube Hardness – Selecting a **Power Tube Type** (above) loads the appropriate “knee voltage” for the selected power tubes. This voltage can be adjusted up or down using Power Tube Hardness. Higher values yield a lower knee voltage and more abrupt clipping and vice-versa.

Power Tube Mismatch – Use this to simulate a gain mismatch between the virtual push and pull power tubes. A value of zero represents perfectly matched tubes.

Bias Trem Frequency, Bias Trem Depth – (Axe-Fx III Only) These create true bias tremolo by varying the bias of the virtual power tubes. Bias Tremolo varies based on a multitude of variables including power amp settings, damping, bias parameters, and more. It is also “self-ducking” and decreases as you play harder. On some amp types, extreme bias depth can result in excessive crossover distortion. On other amps the amount of tremolo can vary greatly between loud and soft playing. All this, however, is part of the allure of bias tremolo as it results in a particularly organic sound. The sound of Bias Trem is available on the FM3 via the Tremolo/Pan block ([p. 91](#)).

POWER SUPPLY PAGE

Supply Sag – This controls virtual power amp dynamics. Higher settings simulate higher power supply impedance, and thus greater tube plate voltage “droop,” for a more compressed feel. This control interacts with the Master and will have little effect if the power amp is not being “pushed hard”. As Master is increased, the power amp draws more current from its power supply and the Supply Sag control will have more effect.



IMPORTANT: Turning Supply Sag fully counterclockwise defeats power amp simulation for a single amp block! This allows it to be used into a real tube power amp without globally disabling **Power Amp Modeling** in **SETUP : Global : Config**. With Supply Sag at 0, **Master** works as a simple volume, **Depth** is deactivated, and **Presence** turns into a simple shelving filter.

B+ Time Constant – This interacts with the **Supply Sag** control because it makes the virtual power supply response slower or faster. When the supply is fast the amp will sag rapidly accentuating the pick attack and compressing after. Most guitar players like this, but setting it too fast will cause excessive AC ripple and ghost notes. For convenience the virtual power supply voltage (B+) is shown as a meter on this page when the Supply Sag control is selected. (The meter shows dB, relative to the idle voltage.)

Supply Type, AC Line Frequency – These select between AC and DC virtual power supply types. AC rectification and resulting supply ripple are modeled, and the line frequency is also selectable. Note that as with a real tube amp, the AC Supply can cause “ghost notes” when **Supply Sag** is low and **B+ Time Constant** is high. Lower B+ Time Constant values will make the amp feel “faster,” but too low can also cause ghost notes.

Variac – This sets the relative AC line voltage into the amp simulation. Volume varies greatly when a Variac is used with a real amp, but the virtual variac compensates for this.

Screen Frequency, Screen Q – These set the resonant frequency of the virtual power tubes’ screen filter, and the Q of that filter.

Level – Duplicated control from the Tone page.

SPEAKER PAGE

These parameters shape the virtual speaker impedance curve and the resulting resonances in the virtual power amp. Amp and speaker interaction affects tone by causing an increase in power amp response at certain frequencies. Note that setting **Negative Feedback** greater than “0” flattens the effect of the response curve.

LF Resonance Frequency, LF Resonance Q, LF Resonance – Guitar loudspeakers have strong low-frequency resonance. This shifts up slightly when the speaker is mounted in an enclosure. This resonance causes an increase in the power amplifier response due to the finite output impedance of the power amp.

HF Resonance Frequency, HF Resonance – A loudspeaker voice-coil presents an inductive load to the power amp at high frequencies. This inductive load, in conjunction with the output transformer capacitance, creates a high-frequency resonance at the specified frequency.

HF Slope – This parameter allows fine adjustment of the high-frequency impedance of the virtual voice coil (which affects the slope of the impedance curve). A speaker voice coil is “semi-inductive” due to eddy current losses in the motor. This presents an impedance to the power amp that is neither fully inductive nor fully resistive. The amount of resistive loss varies by brand and type. Reducing Slope simulates a speaker that is less inductive, increasing Slope simulates a speaker that is more inductive. Typical speakers range from 3.0 to 4.5 with the median being about 3.7. Lower values yield greater midrange while higher values are more scooped and sizzly.

Cabinet Resonance – This parameter interacts with **Speaker Impedance Curve**, located on the Advanced page (p. xx), Changing Cabinet Resonance alters the amount of cabinet resonance in the impedance curve.

Speaker Drive – This simulates distortion and gentle compression caused by pushing a speaker too far. It interacts with the Master which determines how hard the actual power amp is pushing. Don’t overlook this when striving for “vintage” tones as it helps make edge-of-breakup tones sound like an old, well-played amp.

FRACTAL AUDIO BLOCKS GUIDE

Speaker Compression – Even if you never touch most advanced parameters in the Amp block, don't overlook Speaker Compression, aka the "chunka chunka" parameter. It models the interaction of the power amp with the power compression of a virtual speaker. Typical guitar speakers compress between 3 and 6 dB depending upon construction, age, volume, etc. The default value is conservative and yields about 3 dB of compression. **Master**, **Presence**, and **Depth** will interact considerably with Speaker Compression, with higher causing more compression. A gain reduction meter shows the amount of Speaker Compression when this parameter row is selected. Note that this parameter does not reset to its default value when changing the Amp Type.

Speaker Compliance – This control changes the nonlinear behavior of the virtual speaker. Selecting a new amp model or resetting the block will set the value to 50% which is a typical value for guitar speakers.

Transformer LF, Transformer HF – These set the output transformer bandwidth.

Transformer Drive – This models core saturation in the virtual output transformer. Higher values simulate a smaller, more easily saturated transformer. The distortion produced by an overdriven output transformer isn't particularly pretty but it does play a role in the tone and without it the distortion would not be authentic.

INPUT EQ PAGE

The Input EQ parameters adjust a powerful set of filters at the input of the amp block, so its effect is heard before preamp distortion or a front-end tone stack.

Type, Frequency, Q, Gain – These parameters work together to define a powerful multi-mode filter that can be used for anything from a subtle bump to an extreme spike, or from gentle to extreme shelving.

Low Cut – Adjusts the cutoff frequency of a high-pass filter. This control removes bass frequencies and can be useful to tighten an amp's low end, removing "flub".

High Cut – Adjusts the cutoff frequency of a low-pass filter. This filter is actually placed between the preamp and the power amp, so it has a more dramatic effect than an EQ that might be placed before preamp distortion.

Definition – This control is a basic "tilt EQ" which adds highs/cuts lows, or vice versa.

OUTPUT EQ PAGE

The amp block includes a built-in graphic EQ, eliminating the need to use a separate block for tone-shaping. You can achieve different results by changing **EQ Location** in the Advanced menu. To reset the EQ to flat, tap **ENTER**.

To operate the EQ bands, use the **NAV** keys, and **VALUE** or **A,B,C, D** and **E**.

To change the number of bands, use the **NAV UP/DOWN** buttons.

EQ Types (Advanced page) include: 3-Band Console, 3-Band Passive, 4-Band Passive, 5-Band Passive, 5-Band Constant Q, 7-Band Constant Q, and 8-Band Constant Q, 5-Band "Mark", 7-Band Variable Q, and 8-Band Variable Q.

DYNAMICS PAGE

Input Dynamics – Sets the strength of an input dynamics processor. When set below zero, the amp type compresses, resulting in a smoother, less dynamic sound. When set greater than zero, the amp expands, resulting in a punchier, crunchier and more dynamic sound. Note that extreme values can have undesirable side-effects such as pumping or clipping.

Output Compression – This controls the ratio of a compressor specifically tailored to reduce the output dynamic range of the amp block. A gain reduction meter shows the amount of compression when this parameter row is selected.

Compressor Type – Sets the type of **Output Compression**. The “OUTPUT” type simply compresses the output. The “FEEDBACK” type likewise compresses the block output, but also applies dynamics to the input of the block, so you will also get more distortion as you play harder and less when you play softer or roll back the volume. The “GAIN ENHANCER” type simulates the way a loud amp acoustically reinforces the guitar for a more reactive playing experience.

Compressor Threshold – Sets the threshold of **Output Compression**. A lower value causes compression to occur for quieter signals.

Compressor Clarity – Used in conjunction with the other **Output Compression** parameters, this adjusts the bass response of the compressor and can be used to add clarity to the low end.

Speaker Compression – Duplicated control from the Speaker page.

Speaker Time Constant – This adjusts the thermal time constant of the virtual voice coil, affecting the attack and release of virtual **Speaker Compression**. Lower values cause the voice coil to heat and cool faster and vice-versa.

Dynamic Presence – This models output transformer leakage inductance, resulting in a brightening of the tone when the virtual power amp is pushed. When playing softly or at lower gains, the influence of this control is lessened. Note that this only affects the power amp modeling and is dependent on the degree of power amp overdrive. This control can also be set negative to cause the tone to darken when playing harder. This can help dial in the sweet spot of an amp model. As the Master is increased, an amp becomes more liquid, more compressed and easier to play. However, the highs may get overly compressed, causing the amp to sound too dark. Dynamic Presence allows you to get the desired power amp drive and feel without high frequency loss.

Dynamic Depth – Analogous to Dynamic Presence, above. This increases low frequencies when the virtual amp is being pushed. While real amps don't display this behavior, it is a cool tone-shaping tool.

Level – Duplicated control from the Tone page.

ADVANCED PAGE

Input Select – The Amp block processes audio in mono. This control determines how incoming stereo signals will be processed. You can input only “LEFT” or “RIGHT” channels, or “SUM L+R” (the default setting).

Input Trim – Duplicated control from the Tone page.

EQ Type EQ Location, EQ Off/On – These parameters determine the number of bands, location, and on/off status of a **graphic equalizer** built in to the amp block. **EQ Type** sets number of bands and Q behavior (you can also change this from the **Output EQ** page using the **NAV UP/DOWN** buttons.) **EQ Location** sets the position of the equalizer. The default value of “OUTPUT” places the EQ at the output of the virtual power amp. “PRE PA” places the EQ between the preamp and power amp. The “INPUT” setting moves the Post EQ in front of the preamp. The **EQ On/Off** switch can be used to disable the EQ, and this setting can be controlled by a modifier.

Output Mode – The default value, “FRFR”, is designed for use while using “Full Range/Flat Response” monitors, or while recording. The “Solid State Power Amp + Cab” (“SS PWR AMP +CAB”) mode is intended for use while using a solid-state power amp and conventional guitar cab. In this mode speaker compression modeling behaves differently, relying on the speaker for compression while still simulating the interaction with the power amp.

NOTE: The SS PA +Cab Mode is NOT intended for use with “current drive” power amps, i.e. tube power amps, Class-D current feedback amps, etc. This mode CAN be used, however, with FRFR monitors in high volume applications where the monitor’s speakers are compressing, thereby achieving a more dynamic response.

ADVANCED PAGE: TONE AND GAIN SECTION

Here, all of the basic amp controls are presented again for convenience of not needing to leave this page.

ADVANCED PAGE: PREAMP SECTION

Definition – This control is a basic “tilt EQ” which adds highs/cuts lows, or vice versa. It is located at the amp type’s input, so its effect is heard before preamp distortion or a front-end tone stack.

Low Cut Freq – This control filters the lows at the input to the amp.

Hi Cut Freq – This filters the highs at the very end of the preamp simulation. Experiment with this to fine-tune your tone. For example, some of the higher gain amp types are characterized by fairly heavy filtering after the preamp stage. Increase for a brighter tone or decrease for a darker tone.

Tonestack Type – By default, the **Bass, Mid** and **Treble** controls operate as a “passive” tonestack: they simulate exactly the frequency and phase response of the classic passive tonestacks found in the original amplifiers many amp types are based on. This lets you change this behavior from “PASSIVE” to “ACTIVE”, or to substitute the passive tonestack of another amp.

Selecting a substitute tonestack allows you to mix and match amps and tone stacks to create your own hybrids. This allows you to use, for example, a Plexi-type tonestack on a Blackface amp model.

Selecting the “ACTIVE” type gives each tone control +/- 12 dB boost/cut operation for up to twice the range of a typical amplifier. Since the active tone controls are more sensitive, small adjustments have bigger effects. For example, full PASSIVE treble for a high-gain British amp would be equivalent to only +5.0 dB ACTIVE, leaving 7 dB of additional headroom! Active tone controls do not interact like those of a typical amplifier, so when you adjust the treble, the mid and bass are not affected. This can make dialing in a certain tone easier and quicker than it might be with a PASSIVE tonestack.

Tonestack Freq – Sets the center frequency of the tone controls to determine their effect on the sound. This control works whether you are using Active, Passive, or substitute tone stacks. This parameter defaults to an appropriate value whenever you change the amp TYPE, but it can then be changed as desired. But if you subsequently change the **Tonestack Type**, the Tonestack Frequency will not necessarily be correct anymore.

Tonestack Location – Lets you change the location of the tone stack. “PRE” places the tone stack at the input to the virtual preamp, “POST” places the stack between the preamp and power amp. “MID” places it between the last two triode stages, and “END” places it after the power amp (which is physically impossible with a real amp).

Preamp Sag – Turning this ON causes the amp block to behave like an integrated tube head or combo amp. Turning this OFF simulates a separate preamp and power amp.

Preamp Tube Hardness – This parameter controls how sharply the triodes enter saturation and can be used to simulate softer or harder tubes. The lower the value the softer the distortion. Higher values will cause the overtone series to have a less steep decay and will increase perceived “sparkle”. Use this control with Preamp Bias to control how chimy and “round” the tone is.

Triode 1 Plate Freq, Triode 2 Plate Freq – These parameters set the cutoff frequency of the last two triodes in the chain. Many amps have a capacitor across this triode’s plate resistor. This capacitor is used to smooth the response and reduce noise. You can adjust the amount of capacitance, and the resulting frequency, using these parameters.

Preamp Bias – This adjusts the bias point of the last triode stage. This is the most important stage in the feel and texture of distortion, as it controls the ratio of even/odd harmonics. Values around zero will produce mostly odd harmonics. As you deviate from zero you’ll produce less odd and more even. Odd harmonics give clarity and a more aggressive, open tone but this can be cold and harsh. Adding even harmonics gives a warmer sound but too much and things can get muddy. Getting the right balance of even and odd harmonics is one of the keys to achieving “edge of breakup” tones.

Bias Excursion – Not to be confused with Bias Excursion on the Power Amp page, this is a separate parameter for the preamp. The higher the value, the more the bias shifts when the virtual tubes are overdriven.

ADVANCED PAGE: CATHODE FOLLOWER SECTION

Cathode Follower Compression – Determines the amount of compression in the virtual cathode follower. This parameter interacts with the other parameters listed below.

Cathode Follower Harmonics – Simulates harmonics that occur naturally inside an amp as tubes interact. Higher values increase the interaction between virtual tubes, yielding “softer” distortion.

Cathode Follower Hardness – For models that use cathode followers, this adjust the shape, warmth, smoothness and decay of cathode follower distortion.

Cathode Follower Grid Clipping – Adjusts grid clipping in the cathode follower. Lower values reflect the softer response of classic British and American tubes like Mullard, Sylvania and RCA. Higher values simulate the response of modern Chinese and Russian tubes with more abrupt clipping.

ADVANCED PAGE: POWER AMP SECTION

Master Vol Trim – Allows you to adjust the range of **Master Volume**. Increasing the value above 1.0 will cause more gain in the virtual power amp and vice versa.

Master Vol Cap – Sets the value of the bright cap across the **Master Volume** control.

Master Vol Location – Sets the location of the **Master Volume** control. Most amps have the Master Volume before the phase inverter (“Pre PI”). On some amps (like the “Class-A” types) the Master Volume comes after the phase inverter (“PI”). A third option, “pre-triode,” is the default for “Hipower” amp types.

Presence Freq – This multiplier alters the center frequency of the **Presence** and **Dynamic Presence** controls.

Depth Freq – This multiplier alters the center frequency of the **Depth** and **Dynamic Depth** controls.

P.A. Cathode Resonance – There are two types of power tube bias: fixed bias and cathode bias. In a cathode biased amp a resistor is placed between the power tube cathode and ground thereby self-biasing the tube. This parameter sets the value of the virtual cathode resistor. Higher values result in a more negative bias and push operation towards Class-B, resulting in more crossover distortion.

P.A. Cathode Time Const – This sets the time constant of the virtual RC cathode network for amp types that are cathode biased.

PI Bias Excursion – Controls how much the virtual phase inverter bias shifts when overdriven.

Pwr Tube Bias Excursion – Controls how much the grid bias shifts when the virtual power tube grids are overdriven.

Excursion Time, Recovery Time – These parameters are related to **Pwr Tube Bias Excursion**. They control how rapidly the coupling capacitor charges or bleeds off as the virtual power tube grids are conducting or not.

Speaker Impedance Curve – Tucked away near the end of the advanced menu is this remarkable little parameter. It selects between 50+ high-order speaker impedance modeling curves. Changing the amp **Type** will load an appropriate curve automatically. The **Cabinet Resonance** parameter ([p. 13](#)) can be used to adjust the amount of cabinet resonance in the impedance curve, an effect made instantly more visible on the graph shown on the “Speaker” page of the amp block edit menu and in Axe-Edit or FM3 Edit.

ADVANCED PAGE: OUTPUT SECTION

The Amp block has **Level**, **Balance**, **Bypass**, and **Bypass Mode** parameters.

See [“Common Mix/Level Parameters” on p. 7.](#)

THE CAB BLOCK

CAB

The Speaker Cabinet simulator, or Cab block, recreates the tonal characteristics of various different speakers loaded into different cabinets. It also recreates the sound of various mic preamps, room reverb, "air", "proximity", and simulates millimeter-resolution "mic distance" for accurate inter-microphone phase effects.

The Cab Block uses impulse responses (IRs). These are "captures" of real speakers in real cabinets created in a studio setting. With 2,048 factory cabs to choose from, plus a "Legacy" bank with all 189 factory cabs from the Axe-Fx II/AX8. Factory content includes selections from the best of today's 3rd party IR producers and artists.

"User Cab" memories allow you to load our Cab Packs (including any of those compatible with our previous products) or 3rd party IRs. The Axe-Fx III has 2,048 user cab memory locations while the FM3 has 1,024.

The Cab block features a mixer based on our popular Cab-Lab software with up to four different IRs per Cab Block Channel (two on the FM3). This provides the capability to mix and remix IRs on-the-fly as you would do with real mics on a real speaker cabinet.

On the Axe-Fx III, a built-in utility allows you to capture your own speaker IRs –with 16 "Scratchpad" locations for testing IRs without saving them.

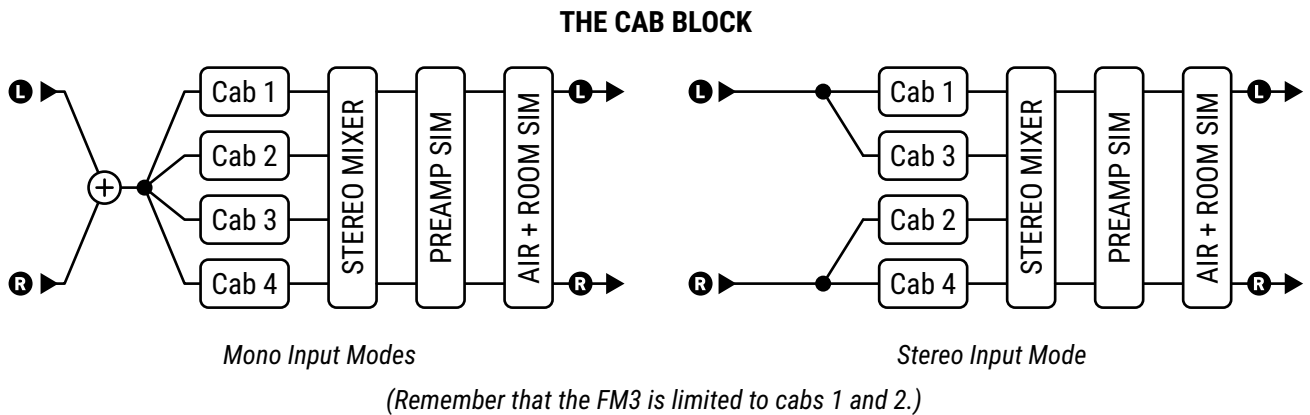

CABS PAGE

The **Cabs** page allows you to select different IRs, with a full column of parameters for each one. The names of currently selected IRs are shown at the top of the page. Each of the following parameters is available for every IR.

Bank – Selects from the various banks containing cabs. The available banks are:

- **Factory 1, Factory 2:** Two banks of 1,024 built-in IRs contain a wealth of selections from the best or today's IR producers and artists, including many taken from Fractal Audio Cab packs produced prior to March 2018.
- **User 1 (Axe-Fx and FM3), User 2 (Axe-Fx Only):** Each banks has 1,024 memory locations for User Cab IRs. Learn more about loading User Cabs in your **Owner's Manual**. (FM3 has one user bank of 1,024.)
- **Legacy:** This bank contains all 189 factory cabs from the Axe-Fx II XL+.
- **Scratchpad:** The 16 Scratchpad locations are designed to allow you to "audition" cabs before committing them to a User Cab slot. This capability is especially useful when capturing IRs or using Cab-Lab (<https://www.fractalaudio.com/cab-lab-3>). Please note that the contents of the Scratchpads are cleared every time you power off.

Cab Number – This selects a specific IR by its number within the current bank.



Cab Picker – With the cab number field selected, press **ENTER** to show the Cab Picker. This lists all IRs in the current bank and makes it easy to scroll through the list to find what you are looking for. On the Axe-Fx III, UltraRes IRs are shown in violet and standard IRs are shown in green¹. Cabs are initially shown in numbered order, but the **Sort A-Z button** (Push-knob A) can be used to sort the list alphabetically. The **Filter** button filters the list, selecting a different cabinet size with each press (or showing FILTER: OFF when the list is not filtered). Filters include: 1x4, 1x6, 1x8, 1x10, 1x12, 1x15, 2x10, 2x12, 4x10, 4x12. Press **EXIT** to leave the **Cab Picker** and return to the Cabs page.

Cab 1, 2, 3, 4 Level – (two on FM3) These parameters may seem straightforward, but can actually be a bit tricky until you understand how they work. Rather than simply controlling the overall level of each Cab IR, this sets *relative* levels between the IRs when more than one is loaded. The final blend is then normalized² and controlled via the **Level** parameter on the **Mix** page—a master control for all four Cab IRs. So, for example:

- When only **ONE** Cab IR is in use and the other three are **muted**, this control will have no effect since *relative* level doesn't apply without two or more Cab IRs to compare.
- When **TWO (or more)** Cab IRs are loaded, you only need to adjust the one(s) you want quieter. Think about it: reducing Cab 1 to -2 dB and Cab 2 to -4 dB is the same as leaving Cab 1 alone and setting Cab 2 to -2 dB. Only the *difference* counts!
- With more than one Cab IR in use, you will hear the *tonal* blend change, but the overall volume will remain relatively the same because again, the blend is normalized as you adjust. Do keep in mind however that because of their frequency contents, some cabs may be *perceived* as louder or quieter than others.

¹ The FM3 loads a truncated version of UltraRes impulses. Its user interface does not distinguish between formats.

² Normalization in this case makes the output signal as loud as it can be without distorting.

Mute/Solo – **Mute** turns any of the IRs ON or OFF. When an IR channel is muted, it uses no CPU, making this one of the parameters you can turn to in order to reduce CPU burden. For reasons discussed above under **Level**, the overall level will not change when you mute one or more IRs. **Solo** mutes all IRs except the selected one.

Pan – Sets where a given IR will be heard in the stereo field.

Mic Distance – Sets the distance of the virtual microphone in millimeters, causing sub-millisecond delays that can be used to create inter-mic phase effects.

Low-Cut/Low Slope, Hi-Cut/High Slope – These adjust the cutoff points and filter slope for high-pass and low-pass filters after the preamp. Increase **Low Cut** to reduce low end, and decrease **Hi Cut** to darken the tone. The **Slope** parameters change filter “steepness”, with 6 dB/Oct being a gradual cutoff and 24 being more extreme.

Proximity – Simulates the classic “proximity” effect of microphones on a cab, causing an increase in bass or low frequency response as proximity is increased.

Smoothing – (Axe-Fx III Only) Reduces the prevalence of notches and peaks that are characteristic of a mic'd speaker. Some may find this effect brings the sound closer to that of a cab “in the room.”

IR Length – (Axe-Fx III Only) Sets the length of the IR. Lower values can result in decreased low end detail and resonance, but will also reduce CPU and potentially increase clarity by eliminating any reflections in the IR itself.

PREAMP PAGE

A microphone preamp can create pleasing musical distortion. This might range from subtle “warmth” to full-on “nasty”. Real mic preamps also offer tone controls which change the sound. The Cab block includes controls to simulate these effects.

Drive – Sets the overall gain of the simulated preamp. Increase for more drive. A VU meter below the knob shows the level into the virtual preamp. As you turn it up and the VU meter approaches or exceeds the 0 dB marker, you will begin to overdrive the preamp.

Saturation – This controls the ratio of even/odd harmonics in mic preamp distortion.

Bass, Mid, Treble – These adjust the tone of the virtual mic preamp.

Preamp Mode – Choose between “HIGH QUALITY” and “ECONOMY” modes which use more or less CPU.

Preamp Type – Selects from various preamp types, each with their own drive characteristics. Options include: Tube, Bipolar, FET 1, FET 2, Transformer, Tape 70us, Tape 50us, Tape 35us, Vintage, Modern, Exciter. Set to “NONE” to bypass the virtual preamp completely, saving some CPU.

ROOM PAGE

Room Level, Room Size – These determine the volume level and virtual size of a stereo room reverb simulator built into the Cab block. Adjust these parameters to achieve anything from slight ambience to a “roomy” room.

Room Shape – These sets whether the virtual space is a ROOM or a HALL. Each has its own sonic properties.

LF Damping, HF Damping – These can be used to dampen low or high frequencies in the virtual room.

Mic Spacing – The room simulator captures early reflections using a stereo pair of virtual microphones. This sets the distance between the mics, changing the sound of the space from narrow to wide as you increase the value.

Room Shape – Selects between Hall and Room reverb types.

Floor Reflections– This sets the level of reflections off of the virtual floor of the room or hall. Floor reflections can play a role in “amp in the room” sound, with different flooring materials contributing differently to the sound.

Room Diffusion– Diffuses discrete echoes in the virtual room, allowing for a smoother sound.

Proximity Freq – Tunes the range over which the “proximity” effect occurs. Amount is set per-IR on the **Cabs** page.

ALIGN PAGE

When recording, it is not uncommon to use more than one microphone on a single guitar cabinet. This allows creative blending of different sonic “colors.” Adjustments to the distance/phase of different microphones is another tone-sculpting tool. Sometimes, mics are painstakingly aligned. In other situations, a slight mis-alignment produces the desired effect.

In the modern studio, various tools make it easy to re-align mic timing for desired phase; the **Align** page of the Cab block is a similar tool for adjusting IR phase. This can be especially when using IRs that have not been minimum-phase processed.

The **Align** page shows up to four superimposed graphs of the currently selected IRs, with knobs allowing visual alignment. To align IRs, turn the **B, C, D** and **E** knobs. This sets the **Mic Distance** parameter, which can also be found on the **Cabs** page. Begin by aligning the first prominent peak towards the left, then adjust by ear.

MIX PAGE

Input Mode – Selects the input mode of the Cab block. Three mono modes allow selecting LEFT, RIGHT or SUM L+R, while the STEREO mode processes L+R input channels independently. (Compare the diagrams on [p. 19.](#))

Air, Air Frequency – Allow add high-frequency “air”, with a cutoff frequency to control brightness.

THE SOUND OF IMPULSE RESPONSES

Fractal Audio Systems amp models and speaker simulation technology are [incredibly accurate](#), yet some listeners find the sound of IRs unfamiliar at first. This is because impulse responses typically recreate the “close microphone” technique. When you mic a guitar speaker, the mic “hears” something very different to what you might hear. Our ears are by definition “neutral” whereas a mic has distinct “color.” We typically listen at a distance (and speaker tone is very different as we move around) while a mic is inches away and stationary, focusing on the desirable sound at a specific spot.

As guitarists, we are accustomed to the sound of a speaker “in the room,” but this is not what our audiences hear. For recording and performing, the **close mic’d** sound is essentially a universal standard. THIS is the sound that the Cab block is designed to reproduce, and this explains why not only guitarists, but recording and front-of-house engineers have embraced its use. Of course our Amp models can also be used with a traditional guitar speaker as shown in many of the setup diagrams in your **Owner’s Manual**.

If you are new to using mics on a guitar amp, you will find the Cab block is a fantastic way to learn more. To get started, listen to single IRs, or explore the factory presets which combine several at once. For almost a century, artists, producers and engineers have refined the craft of placing or blending mics to achieve a desired tone. Many classic techniques are easy to recreate. Try a tried-and-true “recipe” like blending one “bottomy” and one “edgy” mic, or try something totally original.

The factory content includes dozens of speakers with different mics in different positions. You may also enjoy “Mix” IRs by Fractal Audio or 3rd-parties, which bring a producer’s experience to you in a single IR. In any case, recognize that the sound of IRs is the very sound of the speakers and mics they capture.

User Cabs add a whole new dimension to the Cab block. See your **Owner’s Manual** for more information.

THE CHORUS BLOCK

CHO

A chorus unit creates one or more delayed copies of the input signal and modulates each of these to create the layered effect of different voices. Used subtly, the effect can be dimensional and liquid, while more extreme settings can produce a vibrato or “Leslie” effect. The Chorus block offers a high-quality, multi-voice stereo chorus capable of producing anything from exceptionally smooth ensemble effects to a wildly detuned warble, with special modes for some rare vintage effects such as tape chorus, dimension chorus, and tri-chorus.

Chorus is heard on many “80s” tones, especially the “LA Session” sounds of Steve Lukather and Mike Landau. Tom Scholz, Alex Lifeson, Mike Stern, Eric Johnson and many others have famously used chorus.

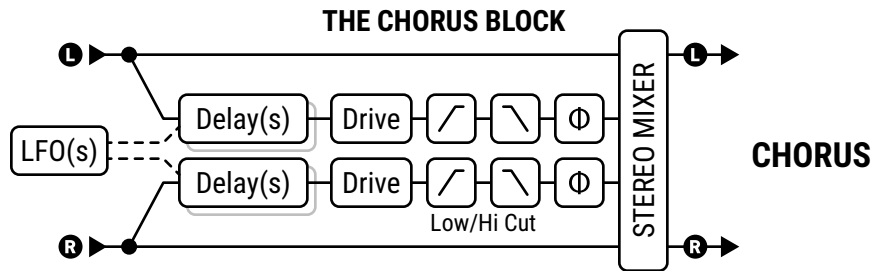

Basic Chorus shown. Some types use variant algorithms.

TYPE PAGE

Type – Make a selection using the **VALUE** or **NAV** buttons with no need to press **ENTER**. This control instantly sets other parameters for different useful sound settings. Types include: **Digital Mono, Digital Stereo, Analog Mono, Analog Stereo, Japan CE-2, Warm Stereo, 80’S Style, Triangle Chorus, 8-Voice Stereo, Vintage Tape, Dimension (1/2/3), 4-Voice Analog, 8-Voice Analog, Stereo Tri-Chorus,** and **Dual Chorus**.

All **Analog** types use an algorithm that models classic bucket brigade (BBD) units. **Vintage Tape** uses a unique algorithm that models the behavior of a tape chorus. **Tri-Stereo Chorus** is based on the coveted original.

BASIC PAGE

Number Of Voices – Sets the number of delay lines. Increasing voices increases the fullness of the effect. Use two voices for a vintage chorus, or use up to eight for a lush, multi-layered ensemble.

Rate – Controls the speed at which the chorus oscillates. Use low settings with higher depths for slow-moving sounds. Increase the rate and depth for vibrato effects. When shown in parentheses, Rate is being set automatically by the **Tempo** parameter. Set Rate fully counterclockwise to sync to the **LF01 Controller**. (See your **Owner’s Manual** for more on the LF01 Modifier Source.)

When the Dual Delay type is selected, individual left and right Rate controls are shown.

Tempo – Sets the **Rate** in rhythmic relation to the tempo. For example, if **Tempo** is set to “1/4” and the Tempo is 120 BPM, the rate will automatically be set to 2 Hz (BPM/60 = Hz). To ignore tempo, set to “NONE”.

Depth – Sets the amount of delay modulation, which determines the amount of detune heard from each voice.

Tip: Rate and Depth are usually adjusted inversely (high rate/low depth or low rate/high depth), but other settings can also produce interesting effects. For greater depth, turn Auto Depth on the Expert page to “OFF”.

When the Dual Delay type is selected, individual left and right Depth controls are shown.

Delay Time – Adjusts the minimum delay time from 0.01–50.0 ms. Lower values create a more singular sound, while higher settings approach a fast “slapback” delay effect.

Mix – Sets wet and dry levels. 50% produces a classic effect. Set to 100% for pure wet or vibrato effects.

📁 EXPERT PAGE

Low Cut – Adjusts the cutoff frequency of a high-pass filter at the output of the processed signal. This control removes bass frequencies and can be useful to create chorus effects designed for bass guitar.

High Cut – Adjusts the cutoff frequency of a low-pass filter at the output of the processed signal. Decreasing this value creates a darker chorus effect reminiscent of an age when typical effects were unable to reproduce the full frequency spectrum. Lower this to achieve those sounds some might call “warm.”

LFO Phase – Adjusts the phase differential between left and right voices, shifting the detune effects for less or more apparent difference between opposing voices.

LFO Type – Sets the “shape” of the modulation. Sine and Triangle are the most commonly used waveforms.

Note: Whenever the number of voices is set to more than two, the LFO type will change automatically to “SINE.” If the number of voices is greater than two and the LFO type is changed to something other than “SINE,” the number of voices will be reset to two.

Auto Depth – Scales **Depth** to create a consistent sound at any **Rate**. This control simplifies dialing in “musical” results. For precise control or wild sounds, you may wish to turn it off.

Phase Reverse – Allows left, right or both channels of the effect to be phase-inverted.

Drive – This control allows you to simulate the gentle distortion produced by overdriving an “analog bucket brigade” delay chip of the type used in many vintage chorus effects. Set to zero for “pristine clean.”

Width – Widens the sound, creating a difference between left and right delay times by scaling the right time downwards from the value set (see **Delay Time**, above) toward 1 ms as Width goes from 0–100%.

LF02 Rate – Adjusts the rate of the secondary LFO. This LFO modulates the primary LFO and can be used to create more interesting effects.

LF02 Depth – Adjusts the depth of the secondary LFO.

Stereo Spread – Controls stereo width by setting the pan position of the effect from hard-panned (100%) to dead mono (0%) – and beyond, with psychoacoustic effects increasing the apparent width from –200% to +200%.

Dimension Mode – Allows simulating the famous “Dimension”-style rackmount and pedal chorus units:

- OFF: Dimension mode is not active.
- LOW: A neutral version with no tonal coloration.
- MED: Classic Dimension processing buttons 1-3. Set Rate to 0.25 - 0.50 Hz and Depth to taste.
- HIGH: Classic Dimension processing button 4. Rate and Depth as above.

Right Time Ratio – When the Dual Delay type is selected, this scales the time for the right chorus.

📁 MIX PAGE

The Chorus block has **Mix**, **Level**, **Balance**, **Bypass**, **Bypass Mode** and **Global Mix** parameters. See [“Common Mix/Level Parameters” on p. 7.](#)

THE COMPRESSOR BLOCK

CMP

A compressor reduces the difference between loud and soft sounds by reducing the louder portions of a signal. The designated reduction occurs whenever the measured signal exceeds a set threshold. While a compressor reduces the volume of loud sections, it can simultaneously boost overall level for greater perceived sustain.

In guitar pedalboards, a compressor is often placed at the start of an effects chain, though using the effect can increase noise or even squealing. In the recording studio, a compressor is typically placed towards the end of a signal chain to smooth irregular levels or provide special effects. This block includes both pedal and studio-type compressors (detailed below) and allows side-chaining and sophisticated detector signal filtering.

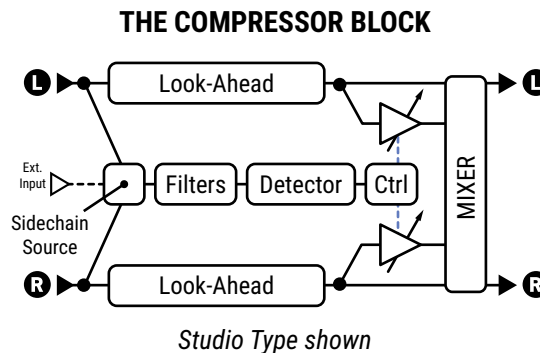

TYPE PAGE

Type – Compressor types include **Analog Compressor**, **Dynamicomp**, **Dynamics Processor**, **JFET Compressor**, **Optical Compressor**, **Pedal Compressor 1**, **Pedal Compressor 2**, **Studio FB Compressor 1**, **Studio FB Compressor 2**, **Studio FF Compressor 1**, **Studio FF Compressor 2**, and **Tube Compressor**.

The **Studio FF Compressor 1** (formerly “Studio”) type simulates a popular style of high-end “Feed Forward” downward compressor. **Studio FF Compressor 2** is similar except that it is an “upwards compressor”. **Studio FB Compressor 1** and **2** are feedback compressors with downwards and upwards compression respectively. In “Feedback” compressors, the detector listens to the output signal instead of the input, yielding a different sound commonly referred to as “fat” with smoother dynamics. Note that nature of feedback compressors can result in distortion at extreme settings (fast attack/release, high ratio, etc.). It is therefore recommended to set **Auto Att/Rel** to ON while using these types.

Pedal and **Optical** types simulate classic types. **Pedal 2** uses a smoother detector which pumps less, while **Optical** offers different light types with different control characteristics. The **Dynamics** type allows compression or expansion with a single control. The **Analog Compressor** has a soft knee and captures the vibe of classic 70s/80s compressors. The **Tube Compressor** is based on classic models like the Altec Lansing 436C and can add the subtle, desirable distortion characteristics of the original. The **DynamiComp** is based on the MXR Dynacomp, and the **JFET** is loosely based on a Urei 1176.

Change the type by using **VALUE** or **NAV** buttons with no need to press **ENTER**.

📁 CONFIG PAGE

Pedal/Optical and Common Parameters

Threshold – Sets the level above which automatic volume reduction will occur. When the input exceeds the threshold, the compressor reduces the output. **Ratio** (below) determines *how much*.

Compression – Determines how compressed the signal will be, decreasing dynamics and increasing sustain. Set low for light compression or high for total squash. An on-screen meter shows gain reduction.

Attack Time – This sets how fast the compressor reduces the volume once the threshold is exceeded. Higher settings will produce a popping attack since more of the uncompressed signal has time to be heard.

Look Ahead Time – Despite fast attack times, a compressor can fail to “catch” very fast transients. This setting introduces a short audio delay so the gain control stage can have “advanced notice” from the detector, which is side-chained with no delay. Higher look-ahead values help reduce “popping,” especially when heavy compression is used on very percussive sources.

Release Time – Determines how quickly the output volume returns to normal once the input level falls below the compressor’s threshold. Fast release rates allow the compressor to bounce back and produce snappy attack, but a setting that is too fast can cause distortion if used in conjunction with fast attack times and high compression or ratio. Slow release times can keep the entire signal quiet, reducing the gain of passages even though they are below the set threshold.

In general the release rate should be set slightly faster than the natural release rate of the program material. An easy way to set the release rate is to strum a chord, watch the gain reduction meter (on PG2 of the Edit menu) and set Release Time so the decay observed is slightly faster than the natural decay of the instrument.

Level – Sets the output level of the compressor.

Auto Attack/Release – Turns dynamic control on or off. Turning this switch ON automatically varies the Attack and Release rates according to the program material; the compressor will respond to faster transients with a faster attack.

Light Type – (Optical Compressor-type only) Three light types each cause the compressor to respond differently. Choose the type found in your favorite hardware compressor, or whichever one sounds best to you.

Studio Parameters

The **Studio** compressor has the same parameters as the Pedal/Optical Types, with these exceptions:

Ratio – Sets the input-to-output ratio for signals above the **Threshold**. A ratio of “2.00” (2:1 compression) means that the compressed portion of the signal will be 1/2 as loud as it was at the input. A ratio of “10.00” (10:1 compression) means that the compressed portion of the signal will be 1/10th as loud as it was at the input.

Setting Ratio to “INFINITE” turns the compressor into a “limiter,” which has an absolute ceiling or “brick wall” which nothing can exceed.

Auto Makeup – When turned ON, this increases the output level to maintain perceived loudness at the current threshold and ratio. The **Level** knob can still be used.

Detector Type – Selects whether the compressor will use RMS (“Root Mean Square” ...formerly known in our products as “Fast RMS”), PEAK detection, or RMS+PEAK detection. RMS is “smooth” and generally used to even out the level of the program material over a long period of time. Peak detection, commonly used with guitar, is useful for fast limiting. RMS+ Peak combines attributes of both: the speed of a peak and the smoothness of RMS.

Knee Type – The knee control “softens” the operation of the threshold and the ratio, introducing gain reduction gradually as signals approach the threshold. With high compression ratios, a hard knee may produce abrupt gain changes. A soft knee produces a more “transparent” effect since it causes the compressor to engage gradually.

Mix – Sets the ratio of wet (compressed) and dry sounds. This would normally be set to 100% but lower settings allow parallel compression, also known as “New York compression.”

Dynamics Processor Parameters

When Type is set to **Dynamics Processor**, the following parameter appears:

Dynamics – When set *below* zero, compression occurs and dynamics are de-emphasized. When set *above* zero, expansion occurs and dynamics are exaggerated. Expansion is basically the inverse of compression. Rather than making loud signals quieter, it makes *quiet* signals quieter, as any signal below the threshold is reduced.

Other controls for this type are the same as their counterparts from the pedal compressors.

📁 SIDECHAIN PAGE

This page is used not only for side-chaining, but also to filter signals before they reach the detector of the compressor. A graph shows the effect of the filters.

Sidechain Source – determines which signal is used to feed the compressor’s detector. “BLOCK L+R” is the normal setting which selects the compressor’s input (sum of the rows feeding the block). You can also use the input from a designated row, and any of the input jacks. The “BLOCK L” and “BLOCK R” options are useful when the compressor follows an effect with one side out of phase (delay, chorus, enhancer). Remember that the Pedal/Optical types use a feedback architecture, in which the output signal is also fed to the detector.

Low Cut, High Cut – These set the cutoff frequencies of high- and lowpass filters shaping the detector signal.

Emphasis – By emphasizing the high frequencies, this high-shelf EQ can prevent thumpy lows from causing the compressor to pump.

Filter Type, Frequency, Q, and Gain – Use this variable filter to selectively boost or cut the detector signal.

📁 MIX PAGE

This block has **Mix, Level, Bypass,** and **Bypass Mode** parameters.

See [“Common Mix/Level Parameters” on p. 7.](#)

FAQ: WHAT IS "PUMPING"? Pumping is an effect that occurs when a sudden strong peaks cause a compressor’s output signal to audibly dip down and up. The event that triggers pumping might be brief, but with attack and release times, its effect becomes more pronounced. To reduce pumping caused by low or high end spikes, you can use sidechain filtering to make the compressor less sensitive to such peaks. Very fast or slow **release times** tend to make a compressor seem more resistant to pumping, but can bring issues of their own. Another option is to switch to a multiband compressor, which handles lows, mids and highs individually. As you might know, pumping can also be used as an effect in itself, such as when a kick drum is set up as a sidechain source to give backing tracks a “bouncing” sound commonly heard in dance music.

THE CROSSOVER BLOCK

Axe-Fx III Only **XVR**

A crossover splits an audio signal into high and low frequency components so they can then be handled separately. This two-way stereo crossover block contains 4th-order Linkwitz-Reilly filters for excellent separation. You can use two crossover blocks to create a three-way crossover by feeding the output of one into the other.

Applications include splitting a signal into two different amps, or creating “multi-band” effects such as polyfuzz or hi-lo chorus.

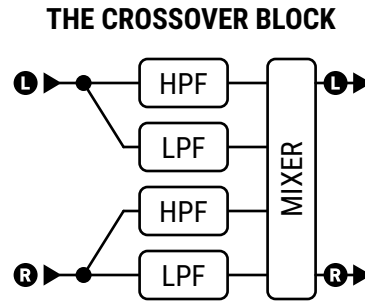

CONFIG PAGE

Frequency – Sets the crossover frequency of the filters.

Frequency Multiplier – When set to “x10,” the crossover frequency is multiplied by ten.

Lo Level Left, Lo Level Right – These set the low-frequency level on left and right channels.

Hi Level Left, Hi Level Right – These set the high-frequency level on left and right channels.

Low Pan Left, Hi Pan Left – These controls allow panning the two Left input bands anywhere in the output.

Low Pan Right, Hi Pan Right – These controls allow panning the two Right input bands anywhere in the output.

MIX PAGE

This block has **Level**, **Balance**, **Bypass**, and **Bypass Mode** parameters.

See [“Common Mix/Level Parameters” on p. 7.](#)

THE DELAY BLOCK

DLY

The Delay block creates classic, modern, and innovative echo effects. Any delay records an input and then plays it back later in time, creating the effect of an echo...echo...echo. Modified tape recorders were once used for this purpose, but these had sound quality, noise, and reliability concerns. Solid-state (“analog”) delays provided an alternative to tape but had shortcomings of their own. The advent of digital technology paved the way for delays with pristine sound, longer times, and superior flexibility, plus the ability to use additional processing to simulate the favorable “nostalgic” qualities of tape, analog, and even lo-fi digital predecessors.

In addition to this block type, additional delay blocks include Multitap, Plex, Megatap, and Ten Tap delay.

TYPE PAGE

Type – This control sets various parameters of the Delay block to achieve popular delay effects instantly. See the table below for a listing of available types. Make a selection using **VALUE** or **NAV** buttons with no need to press **ENTER**.

TYPE	DESCRIPTION
Digital Mono	Full-range, pristine modern digital delay in mono.
Digital Stereo	As above, but stereo in/stereo out.
Analog Mono	Features the frequency response and character of an analog delay.
Analog Stereo	As above, but stereo in/stereo out.
Mono Tape	Special type with dedicated algorithm featuring Motor Speed and other tape controls.
Stereo Tape	A stereo delay with the sonic properties of a tape echo.
Ping-Pong Delay	Echoes bounce from left to right automatically.
Dual Delay	Two delays in one, each with a full set of controls, plus cross-feedback options!
Reverse Delay	This type samples continuously and plays backwards snippets of audio.
Sweep Delay	An LFO controls stereo bandpass filters at the output of a stereo delay.
Ducking Delay	This stereo delay has dynamic ducking to lower echo levels when you play harder.
Vintage Digital	Uses bit-depth reduction for a lo-fi vibe.
2290 w/ Modulation	Based on the legendary original from Denmark.
Ambient Stereo	Ultra-wide echoes with reverb-like diffusion.
Deluxe Mind Guy	Recreates the sound of a classic memory guy delay pedal.
Mono BBD	Mono delay with vintage “bucket brigade delay” tone.
Stereo BBD	As above, but stereo in/stereo out.
Lo-Fi Tape	As mono tape, but very low fidelity to create the sound of a worn-out tape.
Stereo Mind Guy	A stereo version of the deluxe memory guy.

A WORD ON “SPILLOVER”

Like the reverb, the Delay block is capable of “spillover,” which means that effect tails ring out when the effect is bypassed or when you change scenes/presets. See your **Owner’s Manual** for more on Spillover.

CONFIG PAGE

CONFIG PAGE: CONFIGURE SECTION

Mono Types and Common Parameters

The **Mono Delay** algorithm has a great set of features including drive, reverb-like diffusion, dual-LFO modulation, EQ in the feedback path, bit reduction, ducking, and more.

Time – Sets the time of the delay in milliseconds. When shown in parentheses, its value is being set automatically by the **Tempo** parameter (see below). Set **Tempo** to “NONE” to regain manual control.

Tempo – Syncs the **Time** parameter (see above) in rhythmic relation to the tempo. For example, if the tempo is 120 BPM, and Tempo is “1/4” (one echo per beat), time will be 500 ms. To ignore the tempo, set to “NONE.”

Master Feedback – Scales any and all feedback parameters. Note that the range of this control is 0–200%, making it possible (easy, in fact) to overload the feedback loop.

Feedback – Sets the amount of delay feedback (a.k.a. regeneration) to determine the number of repeats. Negative values phase-invert the signal in the feedback loop.

Echo Pan – Positions the echo in the stereo output of the Delay block. Note that this is different than the **Balance** control, which acts on both wet and dry signals.

Repeat Stack/Hold – Use this for Looper-like behavior. Setting the switch to HOLD defeats the inputs and captures the current loop. The STACK option captures the loop but leaves the input to the delay open so you can layer additional material while the repeats continue.

Drive – Determines the amount of distortion in the delay path. Use this to simulate the way cascading feedback overloads a tape or analog delay.

Bit Reduction – This control makes it possible to create the lo-fi sounds of vintage digital delays. The number shown is the number of bits to be subtracted from 24-bit full scale. To create a 16-bit delay, for example, set Bit Reduction to “8” (24 – 8 = 16). Bit Reduction is often used with high-frequency roll-off.

Right Post Delay – Widens the sound of a mono echo by adding 0–100ms of delay at the right (wet) output.

MONO DELAY TYPES

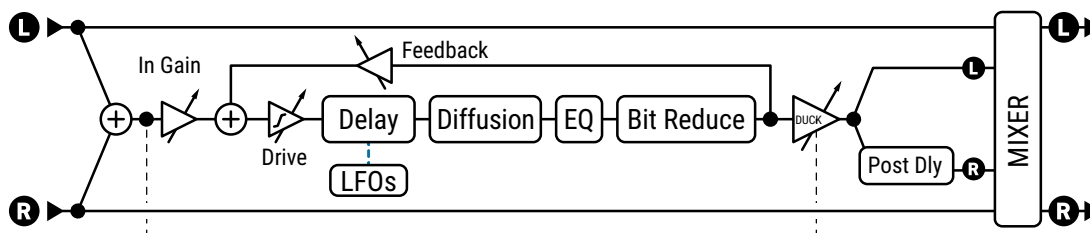

Stereo Delay Parameters

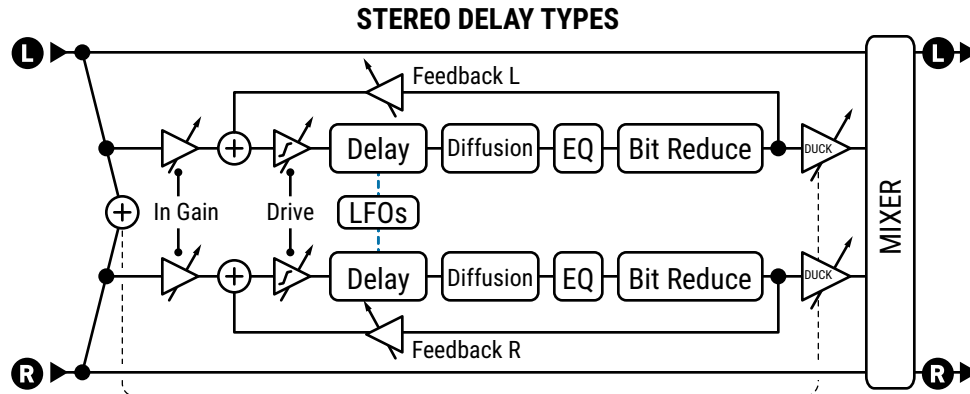

Most parameters for the **Stereo Delay** types work the same as those for the mono types with the exception that the wet signal is stereo-in/stereo out and several additional parameters are available.

L/R Time Ratio – Sets the right channel time as a percentage of the left. 100% results in both channels having equal delay time. Settings just below 100% will widen the echo sound, while ratios corresponding to whole number relationships like 7:8 (87.5%), 3:4 (75%) or 1:2 (50%) will create syncopated rhythm.

Spread (Width) – Controls the overall stereo image width by setting the pan position of the two delays from hard panned (100%) to dead center (0%) to swapped hard pan (-100%).

Feedback L, Feedback R – Stereo delays have independent left and right feedback controls. To preserve “tail” balance, **Feedback R** will be adjusted automatically as **L/R Time Ratio** is adjusted. You may override automatic settings by setting a new value manually. Negative feedback values invert the signal phase in the feedback loop.

Dual Delay Parameters

Dual Delay is identical to the Stereo Delays with the exception that left and right delays are fully independent, with their own **Time, Tempo, Level, Pan** and **Feedback** controls. Dual Delay features a feedback network with four separate parameters. **Feedback L->L** and **Feedback R->R** are the normal feedback controls for each of the two delay lines. **Feedback L->R** and **Feedback R->L** are cross-feedback controls. This structure is illustrated in the diagram at right.

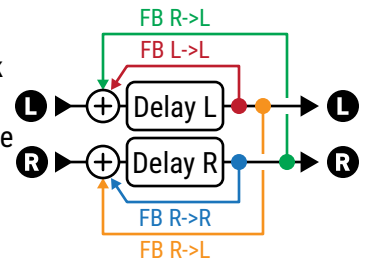

Sweep Delay Parameters

Sweep Delay uses the same algorithm as the Stereo Delay, but adds an LFO-driven stereo bandpass filter after the outputs of the delay.

Start Freq, Stop Freq – These controls set the range of the filter sweeps.

Resonance – Sets the resonance of the filter. Some might describe this as the “intensity” control.

Sweep Type – Sets the waveform of the LFO that controls the sweeps.

Sweep Rate – Sets the speed of the sweeps.

Sweep Tempo – Locks the **Sweep Rate** parameter in rhythmic relation to the **Tempo**.

Sweep Phase – Adjusts the phase of the right outputs of the LFO. Set above zero for stereo effects.

Mono Tape Delay Parameters

The **Mono Tape** algorithm is quite different from other delays. It features two heads and a unique motor speed control with some very cool "analog" behaviors.

Motor Speed – Sets the speed of the tape motor from 50% to 200%. This parameter can be modified in real time, making it possible to “time warp” delay playback.

Head 1 Time – Sets the distance between the virtual record and play heads, in milliseconds. Note that time heard will be shorter if **Motor Speed** is increased above 1.0, or longer if below 1.0.

Head 1 Tempo – Locks the **Head 1 Time** parameter in rhythmic relation to the **Tempo**. See the **Tempo** section under the **Mono Delay** config for more information on tempo and time.

Head 1 Ratio – The Mono Tape Delay has two heads, or “taps” on the loop. This control sets the relative position of the second playback head from zero to a maximum of 100%—the **Head 1 Time** value. Settings close to 100% (e.g. 98%) will widen the echo sound, while values expressing whole number relationships like 7:8 (87.5%), 3:4 (75%), 2:3 (66%) or 1:2 (50%) will create familiar rhythmic patterns.

Level 1, Level 2 – These set playback output level for each of the two heads.

Feedback 1, Feedback 2 – Set the amount from each playback head to be routed back to the recording head to create feedback or “regeneration”. Higher values create a greater number of echoes over time. Because each head replays its own feedback signals plus those of the other head, the sound can very quickly become dense or even out of control—and quite loud. Increase feedback settings slowly, and watch the front panel clip LED as a warning indicator. Lowering **Master Feedback** a bit can help. Negative values phase invert the signal in the feedback loop.

Pan 1, Pan 2 – These position the output of each head in the stereo listening field.

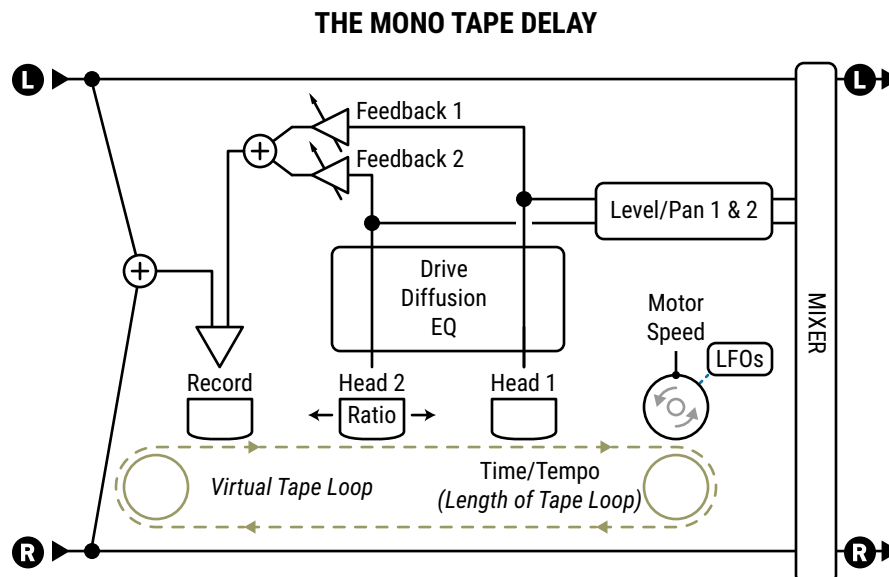

Reverse Delay Parameters

The **Reverse Delay** is based on the Mono Delay type, with differences noted below. The Reverse Delay simulates the impossibility of a performance from the future being heard backwards in the present. It does so by using a delay line to first record for a set time period and then to play that recording backwards. While the first recording plays, the next snippet is being recorded so that reverse playback appears to continue seamlessly. If you can think of your performance as a train, this is like individually reversing each car in place instead of flipping the whole thing from front-to-back.

To hear only the reverse audio, make sure **Mix** is set to "100%."

Time – Sets the length of time that the delay line will "record" before reverse playback begins. This can also be synced using the **Tempo** parameter.

Run – When this is turned ON, reverse playback runs and backward audio is produced. Turning this OFF mutes playback, but recording continues in the background. This switch can be remotely operated with a modifier (such as a footswitch or the Envelope controller) to stop and start playback automatically.

Trigger Restart – The Reverse Delay records audio for a duration determined by the **Time** parameter. While one clip is being recorded, the previous one is played back in reverse. This process runs continuously in the background, meaning the start and end of reversed phrases might not align with the moment you begin playing, even if the recording time is synced to tempo. This parameter helps you gain control over this process. When set to ON, it forces the recording process to re-start at the same moment the **Run** switch turns on. Now, your footswitch (or envelope or MIDI or other Modifier source) not only starts reverse playback, but synchronizes the start of recording too.

Crossfade Time – This extends recording outside of the time window, so backward snippets can overlap briefly and crossfade to create a more smoothly continuous performance.

EQ PAGE

Parameters on this page color the tone of the delay sound (not the dry sound). Use it to produce echoes with the tonal color of vintage technology, or EQ creatively. An on-screen display shows the EQ that is dialed in.

Low Cut, Low Cut Slope, High Cut, High Cut Slope, Q – These define high- and lowpass filters for broad EQ adjustments. **Low Cut** and **High Cut** set the frequencies. The two **Slope** parameters adjust how steep the filter cutoff is. **Q** sets the resonance of both filters. Watch the display as you make changes, but first: Use your ears!

Freq 1, Q1, Gain 1, and Freq 2, Q2, Gain 2 – A pair of 2-band peaking parametric EQs allow boosting or cutting at selected frequencies. EQ 1 is lower range (20 Hz–2KHz) and EQ 2 is higher range (100 Hz–10KHz).

To fill this extra space, here is a small table comparing common delay times in tempo and percentage form. Use the percentage settings for parameters like **L/R Ratio** in the Stereo Delays, or **Head 2 Ratio** in the Mono Tape.

Value	Ratio
1/4	100.0%
15/16	93.8%
7/32	87.5%
1/8 dot	75.0%
1/4 trip	66.7%
"Golden"	61.8%
1/8	50.0%
1/16 dot	37.5%
1/8 trip	33.3%
1/16	25.0%
1/16 trip	16.7%
1/32	12.5%

MODULATION PAGE

This page includes parameters for delay time modulation, plus the ducker, diffuser and output phase controls.

LFO Depth Range – Sets the overall delay time modulation depth to "LOW" or "HIGH" range.

Phase Reverse – Allows the "LEFT", "RIGHT", or "BOTH" delay line outputs to be phase inverted.

MODULATION PAGE: LFO1/LFO2 SECTIONS

LFO1 Type, LFO2 Type – Sets the "shape" of the modulation. Remember that the shift in pitch is determined by the slope of the LFO, so a "TRIANGLE" waveform actually creates a sound that you might expect from a "SQUARE" waveform.

LFO1 Target, LFO2 Target – Sets whether the "LEFT", "RIGHT" or "BOTH" delay line(s) will be modulated. Mono types (including Reverse, Tape, etc.) use only the left delay line.

LFO1 Rate, LFO2 Rate – Sets the delay time modulation speed. When shown in parentheses, it is being set automatically by a **Tempo** parameter (see below). Set the Tempo to "NONE" for manual control.

LFO1 Tempo, LFO2 Tempo – Sets the LFO rate in rhythmic relation to the Tempo. For example, if the tempo is set to "1/4" and the Tempo is 120 BPM, the LFO rate will automatically be set to 2 Hz (BPM/60 = Hz). To ignore the Tempo, set these controls to "NONE".

LFO1 Depth, LFO2 Depth – Sets the depth of delay time modulation. This setting is scaled by the setting for **LFO Depth Range** (above).

LFO1 Phase, LFO2 Phase – Sets the LFO phase offset for the right delay line. This has no effect on Mono delays (including Reverse, Tape, etc.).

MODULATION PAGE: DUCKING SECTIONS

The **Modulation** page also contains the ducking controls. Ducking causes the "wet" level to be lowered automatically when the level of your playing goes above a set threshold. Then, when you play more quietly or pause, the effect volume increases so that the echoes fill the spaces.

Ducker Atten – Attenuation sets the amount by which the effect volume will duck (decrease). A setting of 20 dB, for example, will decrease the echoes by 20 dB when the input level is above the threshold. Set to 0 to defeat the ducker.

Ducker Threshold – Sets the trigger level of the ducker. If the input signal exceeds this value, the delayed signal will be reduced by the amount set with the **Attenuation** control.

Ducker Release – Sets how long it takes for the delay signal to return to normal when the input goes back below the threshold. A short value here causes the ducked echoes to return to full volume very quickly. Longer times cause the levels to swell back more gradually.

MODULATION PAGE: DIFFUSER SECTION

Diffusion – Sets the amount of diffusion, which creates a reverb-like effect to the echoes.

Diffusion Time – Sets the delay time for the diffuser.

MIX PAGE

This block has **Mix**, **Level**, **Balance**, **Bypass**, **Bypass Mode**, **Input Gain**, and **Global Mix** parameters. For convenience, Mix parameters also appear on the **Config** page. See ["Common Mix/Level Parameters" on p. 7.](#)

THE DRIVE BLOCK

DRV

The Drive block contains over 36 different, classic stompbox models, ranging from clean boost to insane gain. The overdrive types ("OD" or "Drive") are based on a cold-cathode tube model and give a warm, mellow drive. The Boost types don't distort much unless the drive is set quite high, but they are great to push an amp or reshape its tone. Distortion types are based on a variety of tube and solid-state models. Fuzz types are based on a hard-clipping distortion and give that beautiful nasty tone.

Drive effects include the basic controls you will find on their real world equivalents: tone, drive, and level, plus EQ controls that allow you to go beyond the original models. Expert parameters allow you to perform advanced modifications and create totally new drive types.

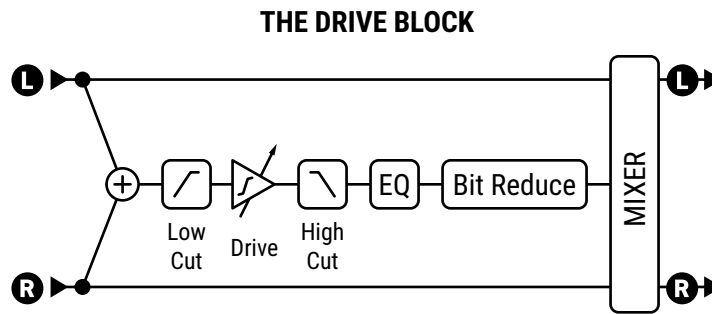

TYPE PAGE

Type – This selects from different models. Select using **VALUE** or **NAV** buttons with no need to press **ENTER**.

TYPE	DESCRIPTION
BB Pre	Based on the Xotic® Pedals BB preamp®.
Bender Fuzz	Based on the classic Tone Bender circuit.
Bit Crusher	Based on a black box we found in the trash outside <i>Studio Harshclip</i> .
Blackglass 7K	Based on Darkglass™ Microtubes B7K bass preamp and drive.
Blues OD	Based on the Marshall™ Bluesbreaker®.
Esoteric ACB	Based on the Xotic® AC Booster®.
Esoteric RCB	Based on the Xotic® RC Booster®.
Eternal Love	Based on a Lovepedal® Eternity.
Face Fuzz	Based on Dallas Arbiter Fuzz Face®.
FAS LED-Drive	Designed by Fractal Audio Systems based on LED clipping.
FAS Boost	Our own take on the boost pedal.
Fat Rat	A modified version of the Rat Dist. A bit fuller and smoother.
FET Boost	A gentle, smooth clipping booster with tone controls.
FET Preamp	Based on... you guessed it: a FET preamp.
Full OD	Based on the Fulltone™ Fulldrive OD Pedal.
Hard Fuzz	A hard-clipping, 60s-style fuzz.
Heartpedal 11	Based on Lovepedal™ OD11
Jam Ray	Based on Vemuram™ Jan Ray
M-Zone Distortion	Simulates the Boss™ Metal Zone™, popular for extreme gain settings.
Master Fuzz	Based on the Maestro Fuzztone, aka "Satisfaction" fuzz.
Micro Boost	Based on MXR™ Micro Amp, an opamp-driven clean boost pedal.

FRACTAL AUDIO BLOCKS GUIDE

Mid Boost	A custom mid-boost overdrive.
Octave Dist	An octave distortion based on the Tycobrahe® Octavia®.
OD250	Based on a DOD Overdrive 250 (gray version)
Pi Fuzz	Based on the Big Muff® Pi fuzz.
Plus Dist	Based on the MXR™ Distortion Plus.
Rat Dist	Based on the Pro Co™ Rat Distortion.
Ruckus Ge	Based on the Suhr™ Riot, a “versatile high-gain distortion pedal” (Germanium voicing)
Ruckus LED	Based on the Suhr™ Riot, (LED voicing)
Ruckus LED/Si	Based on the Suhr™ Riot, (LED/Silicon Diode voicing)
SDD Preamp	Based on the preamp section of the famed SDD digital delay.
Shimmer Drive	An original creation primarily intended as a boost for amps without master volume.
Shred Dist	Based on the Marshall™ Shred Master®.
Super OD	Based on the Boss™ Super Overdrive.
T808 MOD	Captures the most popular TS overdrive mods.
T808 OD	Based on the Ibanez™ TS-9® Tube Screamer overdrive.
Tape Dist	Simulates the clipping of an overdriven reel-to-reel tape deck.
Timothy 1	Based on Paul Cochrane's “Timmy” pedal, with the switch set to symmetrical clipping
Timothy 2	Based on the “Timmy”, with the switch set to asymmetrical clipping
Tone of Kings	Based on the King of Tone by Analog Man™, a sought-after variant Bluesbreaker pedal
Treble Boost	Based on a classic treble booster.
Tube Drv 3-knob	Based on the Tube Driver pedal, that actually contained a 12AX7 (3-knob version).
Tube Drv 4-knob	Based on the Tube Driver pedal, 4-knob version.
Zen Master	Based on Hermida® Zen Drive.

BASIC PAGE

This page contains basic parameters you might find as knobs or switches on actual drive pedals. You can generally use only **Drive**, **Tone**, and **Level** controls and achieve excellent results, but experimenting with the cut and EQ controls unlocks some powerful tone-shaping opportunities.

Drive – Sets the amount of gain/overdrive/distortion/fuzz/boost.

Note: Just as with analog gear, a high-gain drive before a high-gain amp may cause noise and squealing.

Tone – Determines the high/low character of the drive simulation, just as the tone knob on a pedal would.

Mix – Controls the ratio of dry to wet. This should normally be set to “100%.”

Level – Sets the output level. Even a clean-sounding drive can be used to “push” an amp to more distortion.

Low Cut – Controls the frequency of the input highpass filter. Increase to prevent “flubby” distortion.

High Cut – Controls the frequency of the output lowpass filter. Lower this for a darker sound.

Bass/Treble – These adjust the low end and high end from ±12 dB.

Mid – Sets mid boost or cut (±12 dB). Set **Mid Frequency** on the Expert page.

EQ PAGE

This block has a built-in 10-band, 2/3 octave Graphic EQ well-suited to fine sculpting of guitar tones. The EQ can be disabled or placed pre- or post- using the **Graphic EQ** (ON/POST/PRE) parameter on the **Tone** page

ADVANCED PAGE

Clip Type – (Shown only for certain Drive Types.) This controls the type of clipping circuit used, based on accurate models of analog components: 4558/Diode, FET, Full Wave Rectifier, Germanium, Hard, HV Tube, LED, LV Tube, Op-Amp, Silicon, Soft Variable, and Null.

Clip Shape – The “VARIABLE” clip type (above) allows you to dial in a custom clip shape. Low values give a smooth, focused tone while high values give a harder, brasher sound.

Bias – Sets the bias point for the clipping circuit. Varying this setting controls the relative amount of even and odd harmonics. Set very high or very low for a unique “sputtering” effect. Use caution, as setting this too high or too low with certain clipper types can render the block inaudible.

Slew Limit – Limits the large-signal frequency response. Turning up this control simulates the limited high-frequency response inherent in drive pedals using early op-amps. This parameter defaults to an appropriate value when a type is selected.

Mid Frequency – Sets the frequency for the middle band of the EQ on the Basic page.

Bit Reduce – Creates digital distortion by reducing the resolution of the audio signal. The number shown is the number of bits that will be subtracted from 24-bit full scale. To create 4-bit audio, for example, set Bit Reduce to “20.” Yes, it is supposed to sound really gritty and nasty!

Sample Rate – Another nasty lo-fi distortion control, Sample Rate reduction creates intentional aliasing effects.

Dry Gain – While the Drive block has a mix control, many drive effects also include some dry signal in the wet portion of the effect. This parameter controls how much. For types based on a Tube Screamer, this will default to 100% due to the topology. For other types this will default to 0. Values up to 200% are allowed. Note that the dry data is added before any tone controls and therefore is not exactly equivalent to a mix but rather replicates the behavior of analog circuits.

Diode + Type, Diode Quantity, Diode - Type, Diode - Quantity – (Shown only for types based on op-amp and diode clipping) These control the type and number of diodes in the positive and negative polarity. For example, you might select (2) 1N34A diodes for positive signal polarity and (1) red LED for negative. Experiment with the various diode types and quantities to obtain new and unique sounds.

Available types as of this writing include: 1N34A, 1N270A, 1N914, 1N916, 1N4001, 1N4148, 1S1588, 1SS133, BAT41, Blue LED, D9E, D18, FET, FO215, Green LED, MA150, Red LED, and White LED.

MIX PAGE

This block has **Mix**, **Level**, **Balance**, **Bypass**, and **Bypass Mode** parameters.

See [“Common Mix/Level Parameters” on p. 7.](#)

Input Select – The Drive block processes audio in mono. This control determines how incoming stereo signals will be processed. Options include inputting only “LEFT” or “RIGHT” channels or “SUM L+R” (default).

THE ENHANCER BLOCK

ENH

The Enhancer block is used to widen stereo separation, and even converts mono sounds to stereo.

TYPE PAGE

Type – Select using the **VALUE** or **NAV** buttons with no need to press **ENTER**.

- **Modern Enhancer** relies on frequency-based separation of left and right channels to create a widening effect. In comparison to the Classic Enhancer, it does not introduce the risk of phase issues when the signal is later summed to mono, and therefore poses less of a risk for use in presets..
- **Classic Enhancer** delays the right channel by a very small amount to increase the apparent stereo separation between the left and right channels. It also provides individual left and right phase and pan controls. You can use these with or without Width settings as a “channel converter” to reduce width, merge to mono, switch L/R channels, or perform other types of manipulation.
- **Stereoizer** uses multiple high-order filters to create an enhanced stereo image.

CONFIG PAGE

Modern Enhancer Parameters

Width – Determines the character of the effect, shaping the degree of separation.

Depth – Determines how far to the left and right opposing frequency bands will be spread.

Low Cut, Hi Cut – These set crossover frequencies to determine which parts of the signal will be enhanced, and which parts will pass through unmodified. Increasing Low Cut causes lower frequencies to pass through unaffected. Decreasing Hi Cut allows high frequencies to pass through unaffected.

Classic Enhancer Parameters

Width – Sets a delay for the right channel from 0–20 ms. Adjust until the desired effect is achieved. Certain frequencies may cancel each other out at various settings, and effects can vary based on the position of the listener. To set a desired number of milliseconds, divide by 20. For example, 7/20 = 35% so to delay the right channel by 7 ms, set Width to 35%.

Invert – Allows phase inversion of the left or right channel (or both). Use in conjunction with the width control to adjust apparent widening.

Pan L, Pan R – These parameters to control the pan positions of the left and right output signals.

Balance – This changes the relative volumes of the left or right outputs. Sometimes the Classic type causes the Haas effect, which creates a perceived shift in pan away from the delayed side. The Balance control may be used to compensate for this.

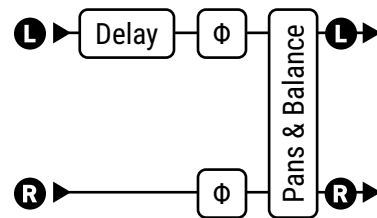

The Classic Enhancer

Stereoizer Parameters

The stereoizer has **Width** and **Depth** controls which determine how separated the output signal will be.

THE FILTER BLOCK

FIL

The stereo Filter block can be used for simple or spectacular sound shaping, allowing a variety of effects. The Filter block is equipped with individual left and right pan controls.

EDIT PAGE PARAMETERS

Type – This selects from different filter types using **VALUE** or **NAV** buttons with no need to press **ENTER**:

- **Null**
- **Low Shelf**
- **Tilt EQ**
- **Low Shelf 2 (passive type)**
- **Lowpass**
- **High Shelf**
- **Feed-forward comb**
- **High Shelf 2 (passive type)**
- **Bandpass**
- **Peaking**
- **Feedback comb**
- **Peaking 2 (Variable Q type)**
- **Highpass**
- **Notch**
- **Allpass**

NOTES:

- The **Null** type has no effect on frequency response but allows gain, phase, pan and other adjustments to be made.
- **Low Shelf 2** and **High Shelf 2** filters recreate the quirky “overshoot” behavior of analog shelving filters found on classic mixing consoles. Set the **Q** between 0.5 and 0.707 to recreate classic sounds or experiment with other settings for different effects.
- The on-screen display makes it easy to see the effects of different filter types.

Frequency – Sets the center frequency of the filter.

Order – Selects different filter slopes. 2nd = 12 dB per octave, 4th = 24 dB per octave. A 4th order filter is steeper and more extreme or “squelchy”.

Q – Sets the “Q” of the filter. Higher values give sharper responses.

Gain – Sets the gain at the center frequency for the shelving and peaking filter types. This is replaced by a **Feedback** parameter when the Allpass type is selected.

Lowcut, Hicut – These first-order filters provide additional tone-shaping capabilities.

Pan L, Pan R – These controls allow you to adjust the placement of the left and right output signals for stereo width adjustment or stereo-to-mono conversion.

Phase Invert – Controls the phase of the output signal with options for “NONE”, “LEFT”, “RIGHT”, “BOTH”.

Delay Time, Depth – For the **FB Comb** and **FF Comb** types, **Delay Time** controls the order of the comb filters. Higher values result in more closely spaced notches and vice-versa. **Depth** controls the intensity of the filter. higher values result in deeper notches/peaks and vice-versa.

CONFIG PAGE: LFO SECTION

A built-in LFO (Low Frequency Oscillator) can be used to dynamically modulate the frequency of the filter. This can create classic auto-filter effects (“No Quarter”, “Ship Ahoy”) or verge into experimental territory.

LFO Enable turns the LFO on or off. **Type** sets its shape. It has typical **Rate** and **Duty** (symmetry) controls. The main filter **Frequency** parameter sets one end of the range, and the **Mod Frequency** sets the other. **LFO Quantize** allows “stepped” effects similar to those heard when a “sample and hold” technique is used.

Mix Page Parameters

The filter block also has **Level**, **Balance**, **Bypass**, and **Bypass Mode** parameters. See [“Common Mix/Level Parameters” on p. 7.](#)

THE FLANGER BLOCK

FLG

The sound of a flanger can be anything from subtle chorusing, to jet-plane swoosh, to robotic drainpipe, to trippy zero-crossing. The sweeping comb-filter sound of the flanger was originally created using synchronized tape decks and shifting one of them out of time by pressing a finger on the “flange” of the tape reel – hence the name of the effect (unless you ask Beatles producer [George Martin](#). . .). Classic examples of tape flanging can be heard in *Itchycoo Park* by the Small Faces, or *Listen to the Music* by The Doobie Brothers.

As technology advanced, pedal and rackmount versions of this effect appeared, simulating the tape effect. These have an amazing legacy in their own right. *Unchained* by Van Halen, *The Spirit of Radio* by Rush, and *Barracuda* by Heart all feature prominent flanger effects.

The flanger has many variants, but almost all of them have a “feedback” control, sometimes called “regeneration” or “intensity”. This returns some of the output signal to the input and intensifies the characteristic sweep, creating a real attention-getting effect. With feedback reduced, a Flanger moves easily into “Chorus” sounds, as exemplified by Andy Summers’ signature use of the “Mistress” type flanger.

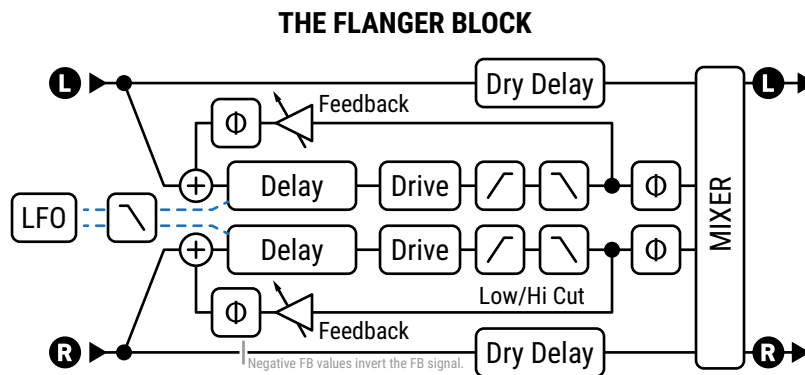

TYPE PAGE

Type – This control instantly sets other Flanger parameters for useful sound settings. Make a selection using **VALUE** or **NAV** buttons with no need to press **ENTER**. Types include: **Digital Mono**, **Digital Stereo**, **Analog Mono**, **Analog Stereo**, **Thru-Zero**, **Stereo Jet**, **Zero Flanger**, **Pop Flanger**, **MXF-117**, **BBF-2 Electric Mystery**, **Deluxe Mystery**, **D/AD 185**, **Manual Thru-Zero Flanger**, and **Step Flanger**.

BASIC PAGE

Rate – Sets the frequency of the LFO (Low Frequency Oscillator) which varies delay time to create the flanger’s characteristic sweep. Use low rate and high depth for slow-moving sounds. Increase the rate for vibrato effects. When shown in parentheses, **Rate** is being set automatically by the **Tempo** parameter (see below). Set Tempo to “NONE” for manual control. Set fully counterclockwise to sync to the global **LFO1** controller (see your **Owner’s Manual** for more on Controllers).

Tempo – Locks the rate in rhythmic relation to the tempo. For example, if the tempo is set to “1/4” and the tempo is 120 BPM, the rate will automatically be set to 2 Hz (BPM/60 = Hz). Set **Tempo** to “NONE” for manual control.

Depth – Sets modulation depth. Higher depths increase the range or magnitude of the sweep. When Depth is at minimum, the Flanger is controlled entirely by the **Manual** control. When Depth is at maximum the delay time is controlled solely by the LFO.

Feedback – This is the crucial “regeneration” control discussed above. Feedback sets the amount of wet signal fed back to the input of the flanger. Extreme values give the flanger a more intense quality as it produces sharp singing resonances or clanging metallic overtones.

Feedback has a range from -100 to +100. Negative values invert the signal phase in the feedback loop, creating sounds with a different character that is more hollow-sounding and even vocal (almost like the sound of oscillator sync on a synthesizer (e.g. *Why Can't this be Love* by VH or *Let's Go* by The Cars). In either direction, extreme feedback settings can cause a siren-like ringing oscillation.

Manual – Flanging is created using a very short delay. The Manual parameter adjusts the time (from 0.01 to 10.00ms) so you can sweep the Flanger by hand. To manually control the flanging set Depth to zero. The sensitivity of the Manual control is inversely proportional to Depth and the Manual control is disabled when Depth is at maximum.

Low Cut, High Cut – These filter the wet portion of the effect signal, gently rolling off lows or highs at the set frequency with a slope of 6db.

Bass Focus – This cuts the bass in the wet path but compensates the dry path so the overall sound is flatter.

Drive – This control allows you to simulate the soft distortion produced by overdriving an analog “bucket brigade” delay chip of the type used in many vintage flanger effects. Set to zero for “pristine clean.”

Monitor – This animated graph shows the shape and position of the flanger’s delay time, whether it is controlled by the LFO or by the MANUAL knob.

EXPERT PAGE

Minimum Time, Maximum Time – These set the time range for modulation or manual control, from as short as 0.340 milliseconds and as high as 20 ms. Shorter times have a higher-pitched resonance. Times are set automatically when you change the flanger **Type**.

Thru-Zero – The Thru Zero switch in the Flanger Block has three modes. Select “**Off**” for normal flanger operation. Select “**Auto**” to sweep the flanger forward and back thru the zero point, with Depth and Manual set as desired (adjust Dry Delay to tune the position of the mid-point). Select “**Manual**” if you want to use the Manual control to simulate the process of tape flanging by hand, with the Minimum position of Manual being zero. For the most dramatic cancellation effects, set Phase Reverse to “Both” and keep feedback low or at 0.



Thru-Zero Flanging is a particular type of flanging effect. As stated in the introduction to this block, Flanging was first created using a pair of analog tape decks playing the same tape at the exact same time. When the relative playback position of one such deck changes, the effect is flanging. “Thru-Zero” flanging happens when one tape goes from being ahead, to being behind the other (or vice versa) – “Zero” being the point where the two decks are perfectly in sync.

Dry Delay – When **Through Zero** (above) is engaged, this allows shifting the cancellation point from the center of the waveform to the edge or anywhere in between.

Phase Reverse – Controls the phase of the wet output signal. Either one or both channels can be inverted. Can be used to widen the sound of a mono flanger or to increase the effect of through zero flanging.

LFO Type – Sets the shape of the modulation LFO waveform.

LFO Phase – Adjusts the phase difference between the left and right LFO waveforms. For maximum stereo spread, set this to 180 degrees. For mono flanging, set this to zero.

FRACTAL AUDIO BLOCKS GUIDE

LFO Bypass Reset – This allows you to force the flanger to start from a fixed point in its sweep cycle when you engage the effect. With the default value of “OFF” the LFO will cycle freely, even when the effect is off.

LFO Hicut – Lowering this control filters the LFO waveform, rounding the edges of sharp turns in its shape. The highest setting of 100Hz is basically unfiltered. Certain waveform types (saw, square, random) can otherwise cause clicks or pops as their values jump from one extreme to another. When you adjust the **Rate** of the flanger, you may need to re-visit this setting. A slower LFO needs a lower Hicut setting to preserve the same effect.

LFO Quantize – This control allows “stepped” effects in which the smooth shape of the LFO is transformed into a series of flat stages similar to those heard when a “sample and hold” technique is used.

Auto Depth – Scales **Depth** to create a consistent sound at any **Rate**. This control simplifies dialing in the sweet spot, but for precise control or wild sounds you may wish to turn it off.

VCO Response, Exponent – Not all flangers are created equal! The various VCO response curves are required to replicate different analog and digital flanger types. This setting changes the shape, excursion, and “dwell” of the sweep. To experiment, try running white noise into a flanger block. Turn up the feedback and listen to the various response settings. **Linear** gives a true linear response. **Exponential** can actually sound more “musical.” The **Exponent** parameter takes effect only when this type is selected. A value of 1.0 is “ideal” and results in the notches sweeping linearly. Higher Exponent values cause the sweep to dwell at shorter times (higher pitch) and then increase rapidly towards the longer times. Lower values cause the delay to dwell at longer times (lower pitch).

MIX PAGE

The Flanger block also has **Mix, Level, Balance, Bypass, Bypass Mode** and **Global Mix** parameters. See [“Common Mix/Level Parameters” on p. 7.](#)

Stereo Spread – Controls stereo width by setting the pan position of the effect from hard-panned (100%) to dead mono (0%) – and beyond, with psychoacoustic effects increasing the apparent width from -200% to +200%.

THE FORMANT BLOCK

FRM

Although the wah effect can be said to mimic the sound of a human voice, it obviously falls a little short in this regard. The talk-box, a system which plays guitar sounds through a tube into a real human mouth, comes far closer to the sound of actual speech, but is a bit unwieldy, requiring a special speaker, mouth tube, and microphone. The Formant filter makes “talk-box” and other vocal effects possible without such a complex apparatus.

A formant is a prominent resonant peak. The human vocal tract is capable of producing different formants which we recognize as different vowel sounds. Filters can be used to reproduce these. For example, the vowel sound “eee” can be reproduced with a bank of narrow bandpass filters with various frequencies and amplitudes.

The Formant block can even blend dynamically between up to three different vowel sounds, called the Start, Mid, and End vowels. It usually sounds best when placed after distortion, although there are no hard and fast rules. The block is stereo in/stereo out and processes left and right channels independently.

CONFIG PAGE

Start Vowel – Sets the start vowel sound from choices shown in the table.
(Regional variations in English pronunciation may result in differences of opinion over which words best represent each sound. Use your ears.)

Middle Vowel – Sets the mid vowel sound.

End Vowel – Sets the end vowel sound.

Resonance – Sets the resonance of the filters. Higher resonance yields a more dramatic effect.

Control – This controls morphing between the three vowel sounds. The start vowel is generated with the knob counterclockwise, the mid vowel at 12 o’clock, and the end vowel at fully clockwise. You can assign this to an LFO, an expression pedal, or other modifier sources. See your **Owner’s Manual** for more on Modifiers.

The Formant block also has **Mix, Level, Balance, Bypass,** and **Bypass Mode** parameters. See [“Common Mix/Level Parameters” on p. 7.](#)

Vowels Table

- AAA as in Bat
- EEE as in Bait
- III as in Beet
- OHH as in Boat
- OOO as in Boot
- EHH as in Bet
- AHH as in Bot
- AWW as in Bought
- UHH as in But
- ERR as in Bert

THE GATE/EXPANDER BLOCK

GTE

The Gate/Expander is sort of a “reverse compressor” that increases the difference between louder sounds and softer sounds by lowering the volume of soft sounds even further. When set up to completely silence incoming signals below a certain threshold, the expander is called a gate.

CONFIG PAGE

Type – Selects between **Downward Expander** and **Classic Gate**. See Ratio and Attenuation (below) for details.

Threshold – This determines how quiet the signal must be before expansion or gating occurs. When input level is lower than the threshold, the expander reduces output volume based on the **Ratio** or **Attenuation** setting.

Ratio (Downward Expander Type) – Determines how much quieter the signal will be when signal level is below the threshold. Think of ratio as the bottom half fn a fraction. A ratio of “4” means you multiply the input level by 1/4 to find the output level (in dB). A ratio of “1.00” would result in the gate/expander having no effect.

Attenuation – (Classic Gate Type) Sets how much quieter the signal will be in dB when the gate is closed. The Classic gate type offers harder gating and is useful for aggressive styles.

Attack – determines how long it takes for the gate to open when signal levels exceed the threshold. You’ll typically want this set low so the attack of your first notes can punch through naturally. Set very high for a “slow gear” effect.

Release – determines how long it takes for the gate to close after signal falls below the threshold. Use a slow setting for a gradual decay to prevent your sustained notes from being gated abruptly, or use a fast setting to have the gate close quickly, stopping noise even between individual notes or phrases.

Hold – Sets how long the Gate/Expander holds the gate open once the threshold has been exceeded.

Sidechain Select – Selects the sidechain input source. “BLOCK L+R” is the normal setting and selects the block input (the sum of all rows feeding the block). The other settings allow isolating a single row or input as the sidechain input. By using a row or input as the sidechain input, you can use the Gate/Expander as a ducker or de-esser.

Low Cut/High Cut – These sets the frequency of low- and hi-pass filters on the sidechain input. The filters only shape the signal feeding the detector. They do not affect the tone of the signal at the outputs.

MIX PAGE

The Gate/Expander block has **Level**, **Balance**, **Bypass**, and **Bypass Mode** parameters. See [“Common Mix/Level Parameters” on p. 7.](#)

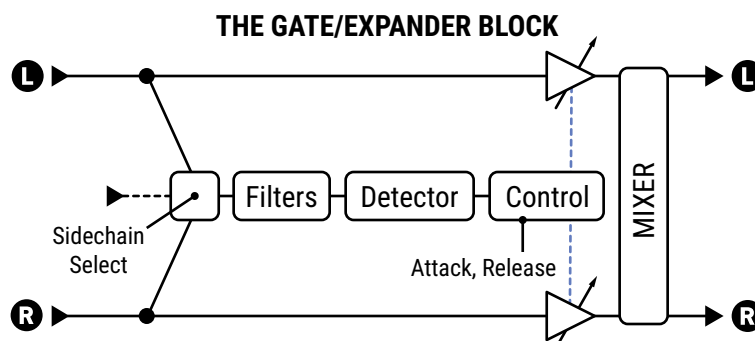

THE GRAPHIC EQ BLOCK

GEQ

The Graphic EQ is a stereo multi-band equalizer consisting of a number of filters spread across the frequency spectrum. This powerful and precise sound sculpting tool is extremely easy to use and understand. Each filter has just one setting, indicating how much to boost or cut at a given frequency.

Type determines the number of bands, and their behavior. Each band can boost or cut up to 12 dB. The outermost bands are shelving filters. The 10-, 8-, 7-, and 5-band types can be run as **Constant Q** or **Variable Q**. In a Variable Q equalizer, the bandwidth varies as a function of boost/cut level, such that lower boosts/cut levels result in a lower Q for a more broad equalization.

	Band 1	Band 2	Band 3	Band 4	Band 5	Band 6	Band 7	Band 8	Band 9	Band 10
10-Band	31	63	125	250	500	1000	2000	4000	8000	16k
10-Band 2/3	100	160	250	400	640	1000	1600	2500	4000	8000
8-Band	80	160	320	640	1250	2.5K	5K	10K		
7-Band	100	200	400	800	1.6K	3.2K	6.4K			
5-Band	80	240	750	2.2K	6.6K					

Several **Passive** EQ types are also offered: **5 band Mark** (based on the EQ found in some MESA/Boogie® amps) **5 band**: (Low, Low Mid, Mid, High Mid, and High), **4-band** (Low, Low Mid, High Mid, and High), and **3-band** (Low, Mid, High), plus a **3-band Console** type. These models capture the quirky “overshoot” behavior of analog filters found on classic consoles.

Master Q (on the Mix page) adjusts the Q or bandwidth of all bands. A value of 1.0 sets the Q to the default value (typically one octave). Lower values increase the bandwidth, making neighboring bands overlap more, while higher values make each band more narrow and focused.

The Graphic EQ block also has **Level**, **Balance**, **Bypass**, and **Bypass Mode** parameters. See [“Common Mix/Level Parameters” on p. 7.](#)



While you’re working on the EQ page, the **A–E** knobs beneath the display allow you to control five bands at once. To switch from the one range of bands to the next, tap **NAV UP** or **NAV DOWN**.

FAQ: HOW TO EQ? This question is discussed in [“The Parametric EQ Block” on p. 60](#). Most of what is stated there also applies to a Graphic EQ. The Graphic EQ has the advantage of being easier to use, but it doesn’t offer the ability to “sweep” frequencies like a parametric equalizer, or see precisely what the EQ curve will be. Not to worry: move from one band to the next and you’ll be able to learn what you **like**, what you **lack** and what you want **less** of.

THE IR PLAYER BLOCK

Axe-Fx III Only

IRP

IR is short for “Impulse Response” – a type of “sonic capture” used by Fractal Audio products for speaker cab simulation and other creative purposes. The IR Player block is in fact a highly simplified version of the Cab block ([p. 19](#)), and like the Cab Block, you can load Factory or User Cabs into it. The difference is that you get only one IR “slot” and none of the bells and whistles, like virtual mic pre, “air” simulation, etc. The IR Player block can also be used to load the output of a Tone Match, leaving the Tone Match block itself available for other purposes.

Bank, Number – Use these parameters to select the desired cab IR.

Length – Sets the IR length from MAX down to 256 samples. Shorter IRs have reduced resonance and use less CPU.

Low Cut, High Cut, Filter Slope – These can be used to apply some basic EQ to the output of the IR player.

Input Mode – Selects the input mode of the block. Three mono modes allow selecting LEFT, RIGHT or SUM L+R.

The IR Player block also has **Level, Balance, Bypass**, and **Bypass Mode** parameters.

See [“Common Mix/Level Parameters” on p. 7](#).

THE LOOPER BLOCK

LPR

The Looper block allows you to create multi-layered looped audio performances in real time. The looper is stereo and features “undo” capability to remove the last recording or overdub. It can be operated from the front panel, or remotely via MIDI/remote or a connected FC Controller.

On the Axe-Fx III, the maximum time is 300 seconds. On the FM3 the maximum time is 120 seconds.

CONTROL PAGE PARAMETERS

Some Looper functions are fired using soft knobs A–E as virtual “buttons”, through a foot controller, or via MIDI.

Record – If the looper is stopped and you press Record, recording begins. If the looper is playing, the Record button normally toggles OVERDUB on or off, but you can change this to PLAY or STOP using the **Record 2nd Press** parameter on the CONFIG page.

Play – This starts and stops playback. If the looper is recording or overdubbing when you press Play, recording or overdubbing stops and playback continues.

Erase – This clears the looper memory. (This function is available only while the looper is stopped.)

Undo – This undoes the last pass of recording or overdubbing. Pressing Undo when the loop is stopped erases all loop data. Pressing Undo during playback undoes the last recorded layer. Pressing Undo again during playback restores the undone layer.

Once – Pressing Once during playback causes the Looper stop automatically when it reaches the end of the loop. Pressing **Once** again while in the middle of a one-shot playback instantly starts the loop, re-triggering playback like a *phr- phr- phr- phrase sampler*. Pressing Once while recording stops the loop. If playback is stopped, Once starts playback from the beginning, plays through to the end, and then stops.

Reverse – This toggles the direction of playback.

Additional Looper Functions on the Config page are accessed by turning knobs A–E:

Trim Start, Trim End – These parameters can be used to adjust the start and end points of the loop. The graph on the Control page provides visualization of the loop and the start/end points. Use the A knob to adjust trim start and the E knob to adjust Trim End.

Threshold – Threshold recording causes the looper to start recording automatically when you begin playing. When set to a value greater than -80 dB recording will not start until the input signal exceeds the set value. The Record icon will blink when the Looper is armed for recording and will turn solid when recording starts. The meter at the bottom of the page can be used to help set the Threshold. Use the soft knob or main Value knob to adjust the threshold value (or use the Record Threshold parameter on the Config page).

CONFIG PAGE PARAMETERS

Playback Level – This adjusts the level of the looper.

Dry Level – This adjusts the level of the level of the dry signal passing through the Looper.

Overdub Level – This works like a “Loop Decay” control, attenuating the level of previously recorded material in comparison to overdubs. (Think of it as similar to the “feedback” control on a delay). If you never want old layers to decay, set this to 0 dB, but be aware that layers can add up and potentially cause clipping.

Crossfade – This crossfades the loop ends for smoother transitions.

Loop Quantize – This forces the loop length to a whole number of beats, as defined by the tempo.

Record Threshold – This is a repeat of the same parameter on the **Control** page.

Record 2nd Press – There are three options for what happens when you press RECORD again while Recording:

Overdub – Recording ends, Playback begins, and Overdub recording is turned on.

Play – Recording ends, Playback begins

Stop – Recording ends, Playback is stopped.

Speed – This is a repeat of the same parameter on the **Control** page.

Low Cut, High Cut – These allow gentle filtering of the looper at its output. These controls affect playback only and have no effect on the sound of material that is being recorded.

The Looper block also has **Bypass** and **Bypass Mode** parameters.

See [“Common Mix/Level Parameters” on p. 7.](#)

THE MEGATAP BLOCK

MGT

The Megatap Delay is a 4 second, 64-tap delay line with parametric control of time, amplitude, and panning. This effect can be used to create interesting sonic patterns/textures or to increase density before other effects.

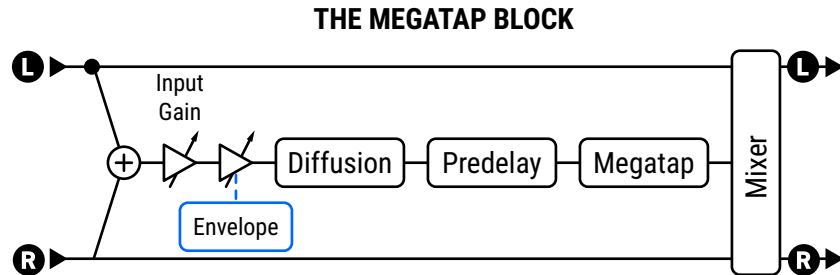

CONFIG PAGE

Input Gain – Sets the input level to the effect, allowing for interesting control opportunities when a modifier is attached. For “swell” effects, the Megatap block also includes a built-in envelope follower which scales the input gain independently of this setting.

Master Level – Controls the overall level of the delay.

Delay Time – Sets the delay time of the last tap.

Number Of Taps – Sets the number of taps (repeats) from 1 to 64. Taps are distributed between the dry signal and the last tap, whose position is set by the **Delay Time** parameter (above). The three examples below shows a delay time of 1000ms with 2 taps, 6 taps and 24 taps.



The **Time Alpha** parameter (see below) changes the timing between taps.

Predelay – This delays the entire Megatap effect by up to 1 second. Because the megatap can create echo density that borders on reverb, this affects perceptions of space caused by the effect.

Time Alpha – Sets the rate of time change across the taps.

An Alpha of 1.00 spaces all taps evenly across the delay time, as shown in the examples above.

Alpha values lower than 1 *decrease* the time between each tap and the next:



Alpha values greater than 1 *increase* the time between each tap and the next:



Time Randomize – This scatters the positions of the individual taps along the time line.

Amplitude Shape, Amplitude Alpha – These control changes to the level of individual taps over time. Shape sets a pattern of changes (increasing, decreasing, etc.) and Alpha determines how the change varies over time.

FRACTAL AUDIO BLOCKS GUIDE

Pan Shape, Pan Alpha – These control changes to the panning of individual taps over time. Shape sets a pattern of changes (increasing, decreasing, etc.) and Alpha determines how great the change will be over time. With a shape setting of “CONSTANT”, Pan Alpha becomes a simple pan control (0% = left, 100% = right).

Diffusion Mix, Diffusion Time – These set the level and time of an input diffuser, which adds a reverb-like effect to signals prior to the Megatap, thickening the tail and smearing transients to reduce the prevalence of individual echoes.

CONFIG PAGE: ENVELOPE FOLLOWER SECTION

Delays are frequently used after a volume pedal or volume envelope for “swells” of ambient sound. The Megatap block has a built-in input envelope follower which controls the input gain to the effect.

Threshold, Attack, Release – These set the threshold level and times for the input envelope. Tip: For a basic volume “roll up” setting, try Threshold: -70.0 dB; Attack: About 400 ms; Release: about 15 ms.

MIX PAGE

The Megatap block has **Mix, Level, Balance, Bypass, Bypass Mode, Input Gain** and **Global Mix** parameters. See [“Common Mix/Level Parameters” on p. 7](#).

THE MIXER BLOCK

MIX

The Mixer block can mix different stereo signals into one stereo or mono downmix. It has six inputs (four on the FM3) and six pairs of gain and balance controls.

The six mixer channels are “hard-wired” to the six grid rows of the column directly to the left of the mixer block. In the example shown on the right, the **Filter** is on Row 1, so the **Row 1 Gain** and **Row 1 Balance** parameters of the mixer will determine how the signal from the filter is passed to the mixer’s output. The **PEQ** is on Row 2, so the **Row 2 Gain** and **Row 3 Balance** parameters of the mixer will determine how the signal from the PEQ is passed to the mixer’s output, and so on.



Empty rows are still counted. For example, if only the Compressor block were connected to the mixer, the Row 3 controls would still be used because the compressor is on row 3.

All six mixer inputs are stereo. The **Balance** for a given row controls the left/right input balance for that channel. When the balance for an input channel is set fully left, only the left channel of that channel will be heard at the mixer’s output. (Remember that even blocks which process audio in mono still have both Left and Right outs, as well as their own output Balance controls.

Gain Rows 1–6 – These controls scale the level of signals at the six mixer inputs from 0–100%.

Balance Rows 1–6 – These controls set the left-right balance of signals at the six mixer inputs.

Mono/Stereo – This determines whether the output of the mixer is stereo or summed mono.

The mixer also has a master **Output Level** and **Output Balance** controls. The mixer block cannot be bypassed.

THE MULTIBAND COMPRESSOR BLOCK

MBC

The Multiband Compressor can be used to shape dynamics and tone, providing independent compressor settings for low, mid, and high frequency bands. The basic principle of a Multiband Compressor is that the input is divided into different frequency components using a crossover. Compression is applied to the bands individually before they are recombined. This allows you to apply different types or amounts of compression to each. Multiband compression is a standard mastering tool and can greatly improve a final mix or a complex guitar sound. It makes the continuity of low frequencies less susceptible to pumping caused by the snap of pick attack.

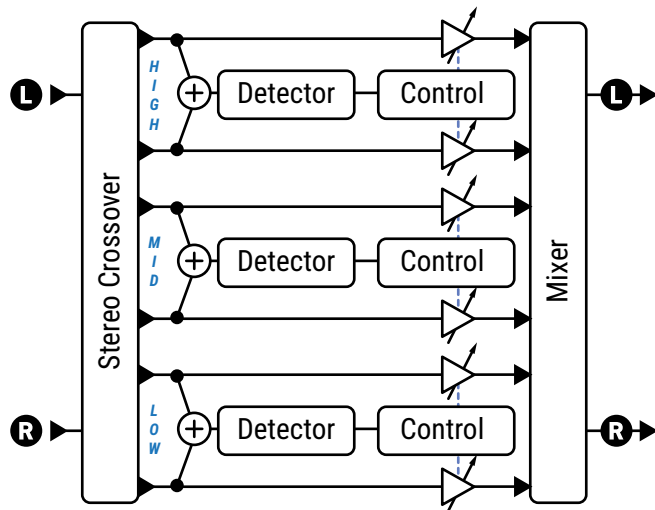

CONFIG PAGE PARAMETERS

Crossover Frequency – These two pairs of parameters set the ranges and crossover frequencies that divide the Low and Mid bands (from 50–500 Hz or 500–5000 Hz), and the Mid and High bands (from 100–1000 Hz or 1000–10,000 Hz). As the Low Crossover is increased, the high value may adjust itself upwards, maintaining a minimum bandwidth of one octave for the mid band.

Threshold – Sets the threshold above which compression will occur.

Ratio – Sets the input-to-output ratio for signals above the threshold. A ratio of 2.00 (2:1) means an increase of 2 dB is needed at the input to produce an increase of 1 dB at the output.

Attack – This sets how fast the compressor acts once the threshold is exceeded. Higher settings may produce a popping attack since more of the uncompressed signal has time to come through before compression is applied.

Release Time – Determines how quickly the output returns to normal once the input level falls below the compressor’s threshold. Fast release rates allow the compressor to bounce back quickly, but a setting that is too fast can cause distortion if used in conjunction with fast attack times and heavy compression. Slow release times keep the signal quiet longer, for example when a “spike” reduces the level which then requires time to return.

Ratio, Threshold, Attack and **Release** parameters work together to determine the amount and responsiveness of compression for each band. The effects of these settings can be observed in on-screen meters.

Level – Sets the output level of the selected band.

Detector – Selects whether the compressors use RMS (“Root Mean Square”) or Peak detection. RMS is “smooth” and works well to even out program material over longer time periods. Peak detection, commonly used with guitar, is useful for fast limiting.

Mute – Mutes the output of the band. By muting two bands, you can solo the third. By muting one band, you can focus on its contribution to the overall mix.

Crossover Slope – The filters dividing the bands can be set to 12 or 24 dB per Octave.

MIX PAGE

The Multiband Compressor block has **Level, Balance, Bypass,** and **Bypass Mode** parameters. See [“Common Mix/Level Parameters” on p. 7.](#)

THE MULTIPLEXER BLOCK

MUX

The Multiplexer block or “MUX” is an input switching powerhouse. It combines various input sources into one block—including two USB options—and can also be used for on-grid switching between rows. No gap is heard when switching sources.

CONFIG PAGE

Input Select – This lists all of the possible input sources and selects which one is active. Only one input can be active at a time. (For multiple inputs, use the **Mixer** block.) Signals from **Inputs 1–4** and **USB 5/6** and **7/8** are present in the Multiplexer without the corresponding blocks needing to be placed on the grid at all. A modifier can be attached to the **Input Select** switch.

This block also has **Level**, **Balance**, **Bypass**, and **Bypass Mode** parameters. See [“Common Mix/Level Parameters” on p. 7.](#)

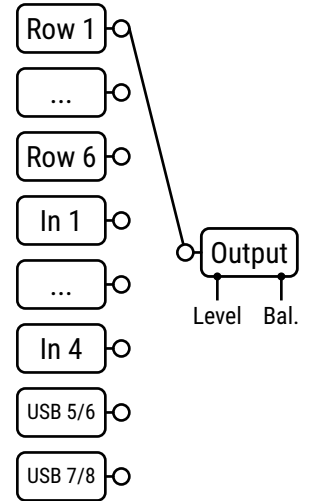

EXAMPLE

The example below shows one possible use of the Multiplexer, used here to select any one of four different drive pedals.



THE MULTITAP DELAY BLOCK

MTD

The Multitap delay uses up to four delay “taps” to create echoes in intricate patterns and rhythms. To understand the concept of taps, imagine one tape with multiple playback heads, or a turntable with multiple stylus arms. The source material remains the same, but each tap picks it up at a different place/time and can be panned, filtered, and modulated independently. The different types provide a fantastic range of creative possibilities.

TYPE PAGE

Type – Make a selection using the **VALUE** or **NAV** buttons with no need to press **ENTER**.

- **Quad-Tap Delay** – offers four independent delay taps with many extras. A truly creative delay experience.
- **Quad Parallel Delay** – extensive delay options with built in ring mod, diffuser, bandpass filter, and comb filter.
- **Quad-Series Delay** – uses a very cool and unique feedback structure, comb filter, and ring modulation.
- **Diffusor** – creates a plex of compound feedback, offering the ability to add density or even create reverbs.
- **Quad Tape Delay** – uses our proprietary tape delay model with four taps for “space echo” effects.
- **Quad Tap Band Delay** – Identical to the Quad Tap delay, except the Bandpass filters are outside the FB loop.

Several of the above types are illustrated below and on the next page.

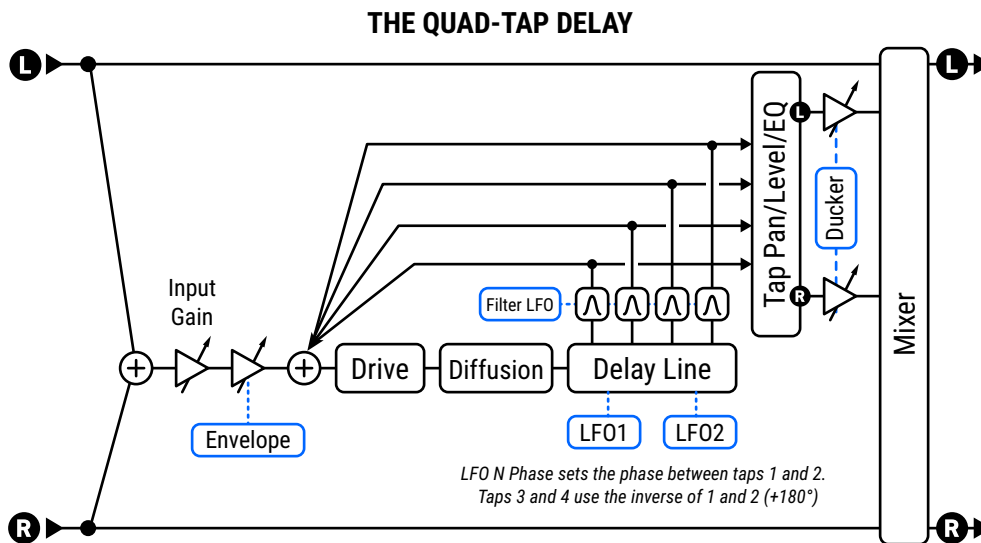

THE QUAD-PARALLEL DELAY

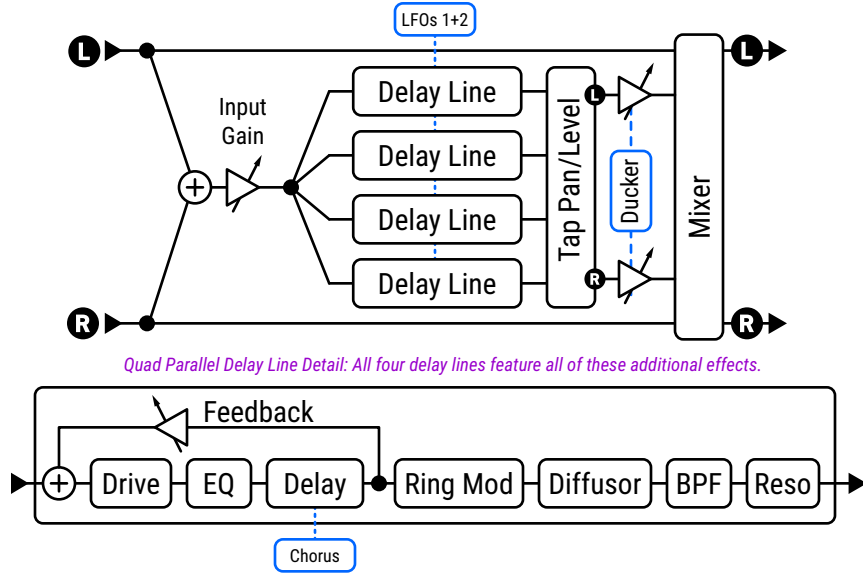

THE QUAD-SERIES DELAY

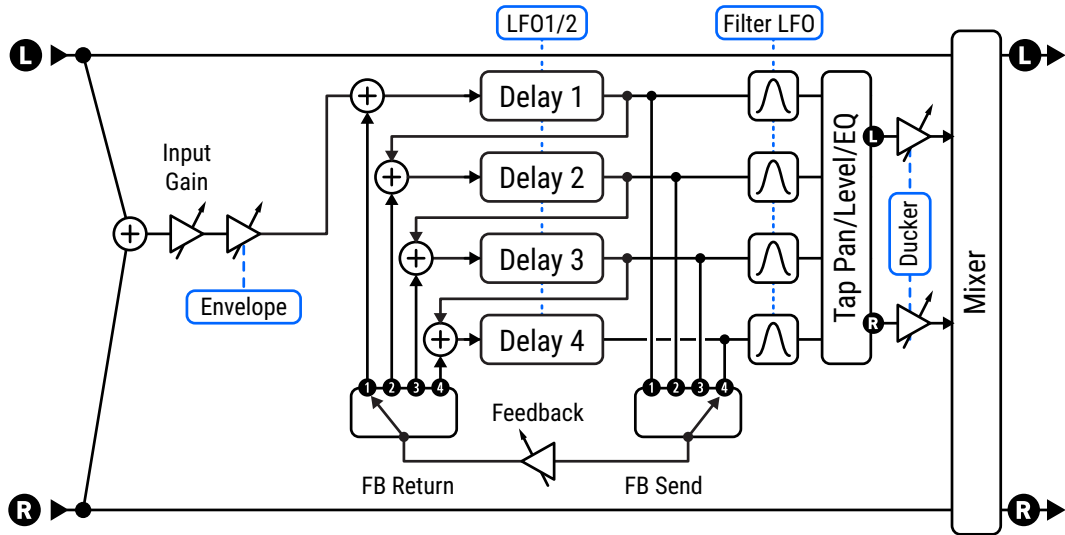

CONFIG PAGE

Quad-Tap and Common Parameters

CONFIG PAGE: MASTERS SECTION

Master parameters are detailed below. These scale the effects of other parameters and can be controlled with a modifier for interesting real-time changes. If a given type doesn't have certain controls, it will also lack the corresponding master for those controls (ex: the Diffusor type has no Pan controls, so it lacks Master Pan).

Master Time – Scales the times of all taps.

Master Feedback – Scales the feedback settings for all taps.

Master Level – Scales the output levels of all taps.

Master Pan – Scales all tap pan amounts, essentially acting as a “width” or “spread” control. Negative values reverse pan positions in left and right channels.

Master Frequency, **Master Q** – These scales the filter frequency and slope for all taps. You can create dynamic filter effects by using a modifier to change this parameter in real-time, but don't set Q values too high or too low, or the filter may be difficult to notice.

Master Comb Time, **Master comb Feedback** – For types with comb filters, these scale time and feedback.

Master Ring Mod Frequency, **Master Ring Mod Mix** – For types with ring mod, these scale the effects.

Master Rate, **Master Depth** – These scale the Rate and Depth of all LFOs

Low Cut Frequency, **High Cut Frequency** – These simple filters affect the entire wet mix.

Drive – Use drive to add distortion to the echoes and can be used to add a saturation effect.

CONFIG PAGE: DELAY LINES SECTION

Time 1,2,3,4 – Sets the time when the selected tap will be heard, from 0-2000 ms. When any Time is shown in parentheses, it is being set automatically by the corresponding **Tempo** parameter (see below). Set Tempo to “NONE” for manual control.

Tempo 1,2,3,4 – Sets the corresponding **Time** parameter in rhythmic relation to the Tempo. For example, if Tempo 1 is set to “1/4” (one echo per beat), the time for Tap 1 will match the tempo.

Feedback 1,2,3,4 – These set the overall feedback blend. See the various diagrams to better understand how feedback is created. Negative values cause the signal to be phase inverted.

CONFIG PAGE: LEVEL/PAN SECTION

Level 1,2,3,4 – These set the level of the selected tap in the stereo mix.

Pan 1,2,3,4 – These set the pan for the selected tap in the stereo mix.

CONFIG PAGE: FILTERS SECTION

Four **bandpass** filters inside the feedback loop allow gentle or extreme tone sculpting of the individual tap delays.

Frequency 1,2,3,4 and **Q 1,2,3,4** control the center frequency and bandwidth of the filters. These filters use a constant power algorithm so higher Q values increase the gain of the filter and can cause extreme effects (guard against runaway feedback!) To get a sense of the sound and “shape” of these filters, you can study the Filter block when it is set to a 2nd order Bandpass type. TIP: To disable these filters, set **Master Q** to its minimum setting.

CONFIG PAGE: LFOS SECTION

LFO1 and LFO2 modulate Delay Times. Each LFO has the following parameters:

Type – Sets the shape of the modulation LFO.

Phase – Offsets the phase of the modulation LFO across the four delay lines. Specifically, the value shown is the phase for **Tap 2**. Tap 3 is 180° out of phase with Tap 1, and Tap 4 is 180° out of phase with Tap 2. So, for example, the default setting of 90° results in phase/offsets of: 0°, 90°, 180°, 270°.

Rate – These set the speed of the modulation LFO. When any **Rate** is shown in parentheses, it is being overridden by a **Tempo** parameter (see below). Set Tempo to “NONE” for manual control.

Tempo – Sets the LFO rate in rhythmic relation to the Tempo. To ignore the Tempo, set these controls to “NONE”.

Depth – Sets the depth for the modulation LFO.

CHORUS SUBSECTION

For types with Chorus, four individual LFOs modulate the four delay voices independently.

Chorus LFO Rate, Chorus LFO Depth (1,2,3,4) – For types with chorus, each voice also has an independent Chorus LFO. By setting the delay times short (2–20 ms), you can create chorus effects even more lush than those of the legendary Tri Chorus or the Quad Chorus from previous generation products by Fractal Audio.

FILTER LFO SUBSECTION

The filter LFO has the same basic controls as LFO1 or 2 (detailed above). The difference is that it modulates the frequencies of the four bandpass filters (The FILTERS section is detailed on [p. 56](#))

CONFIG PAGE: DIFFUSER SECTION

Diffusion Mix, Diffusion Time – Sets the level and time of the diffuser, which introduces a reverb-like effect.

CONFIG PAGE: DUCKER SECTIONS

Ducking causes the wet level to be lowered automatically when the level of your playing goes above a set threshold. When you play more quietly or pause, the effect volume increases so that the echoes fill the space.

Threshold – Sets the trigger level of the ducker. If the input signal exceeds this value, the delayed signal will be reduced by the amount set with the **Attenuation** control.

Attenuation – Sets the amount by which the effect volume will duck (decrease). A setting of 20 dB, for example, will decrease the echoes by 20 dB when the input level is above the threshold. Set to “0” to defeat the ducker.

Release Time – Sets how long it takes for the delay signal to return to normal when the input goes back below the threshold. A short value here causes the ducked echoes to return to full volume very quickly. Longer times cause the levels to swell back more gradually.

CONFIG PAGE: ENVELOPE FOLLOWER SECTION

Delays are frequently used after a volume pedal or volume envelope for “swells” of ambient sound. The Multitap block has a built-in **input envelope follower** which controls the input gain to the effect.

Threshold, Attack Time, Release Time – These set the threshold level and times for the input envelope. Tip: For a basic volume “roll up” setting, try Threshold: -70.0 dB; Attack: About 400 ms; Release: about 15 ms. Increase **Attack Time** for a slower fade in.

Quad Parallel Delay Parameters

The **Quad Parallel Delay** type (illustrated on [p. 55](#)) features four delay lines, each with a great collection of effects. (Four of each: Ring Modulator, Diffuser, Bandpass filter, Comb Filter, and Chorus.) Most parameters are similar to those covered under Common Parameters ([p. 56](#)). Exceptions are detailed below.

CONFIG PAGE: COMB FILTERS SECTION

Comb Filter Time (1,2,3,4) and **Comb Filter Feedback (1,2,3,4)** – These control the settings for four comb filters, one per delay line. Be sure to adjust Master Comb Depth above the default value of 0% if you want to hear these effects.

CONFIG PAGE: RING MODULATORS SECTION

Ring Mod Frequency (1,2,3,4) and **Ring Mod Mix (1,2,3,4)** These control the settings for four ring modulators, one per delay line. Be sure to adjust Master Ring Mode Mix above the default value of 0% if you want to hear these effects.

Quad-Series Delay Parameters

The **Quad-Series Delay** places four delays in series with a very cool and unique feedback structure. The delay lines are connected end-to-end so that their times are compounded as the signal travels from one to the next. Each line has its own output tap, however, so you can hear each tap as it enters the next in line. Feedback is controlled by four parameters:

Feedback – Sets the total feedback.

Feedback Send – Specifies which delay output (1–4) should be fed back to the input.

Feedback Return – Specifies which delay input (1–4) the feedback is returned to.

Diffusor Parameters

A Diffusor uses feedback delays to increase density and layers. It “smears” transients to create interesting reverb-like effects. At some Time and Feedback settings, taps can be heard individually, but diffusion is typically used to create more of a “wall of sound” effect. The Diffusor type in the Multitap Delay block is comprised of four two-second diffusors in series using the following parameters:

Master Feedback – Sets the feedback amount to determine density. Together with the individual delay time settings, this determines the character of the effect and the amount of “smear.”

LFO 1 Rate – Sets the rate of modulation to add a chorus-like sound to the tail of the effect.

LFO 1 Tempo – Synchronizes modulation to a rhythmic value in relation to the Tempo.

LFO 1 Depth – Sets the modulation depth to determine the intensity of time variations/chorusing.

Time 1,2,3,4 – Sets the time of each diffuser from 0-2000 ms. When shown in parentheses, it is being set automatically by the corresponding **Tempo** parameter (see below). Set Tempo to “NONE” for manual control.

Tempo 1,2,3,4 – Sets the corresponding **Time** parameter in rhythmic relation to the Tempo. For example, if the Tempo is 120 BPM, and Tempo is set to “1/4” (one echo per beat), Time will be 500 ms. To ignore the Tempo, set to “NONE.”

DIFFUSOR EXAMPLE

Since the Diffusor borrows many of its default settings from the other Multitap delay types, you may not immediately get classic sounds when you select it. Try the following settings for a lush reverb-like blanket effect.

Begin by resetting the channel and then setting its type to “DIFFUSOR”. Now make the following settings:

Time 1: 400 ms **Time 2:** 647 ms **Time 3:** 1047 ms **Time 4:** 1694 ms

Change all four **Tempo** parameters to “NONE”.

Now we’re ready to listen to these very long times. Play a short sharp note or noise and listen to how the echoes build in density as they feed back into each other. Now lower the Master Time to 50% and repeat the test. Now lower Master Time further to about 20% and you’ll start to understand how what sounds like a clutter of echoes at long times becomes a rich reverb-like diffusion effect at shorter times. Experiment with other Time and Feedback settings, modulation, and even Tempo to vary the texture of the effect.

Quad-Tape Delay Parameters

The Quad-Tape Delay type is almost identical to the Quad-Tap type with a key exception being that it uses our proprietary Tape Delay model featuring a **Motor Speed** control to vary the speed of the motor/tape. To hear the classic “time warp” effect, set feedback controls high enough and then vary Motor Speed. This type does not have an input envelope follower built-in.

MIX PAGE

The Multitap Delay block has **Mix**, **Level**, **Balance**, **Bypass**, **Bypass Mode**, **Input Gain** and **Global Mix** parameters. See [“Common Mix/Level Parameters” on p. 7.](#)

THE PARAMETRIC EQ BLOCK

PEQ

The five-band parametric equalizer is a precise and flexible tone-shaping tool. It lets you focus on specific frequencies, boost or cut as needed, and specify how the change should affect neighboring frequencies. While you work, a graphical display depicts the response, with parameters shown on one screen for convenience.

EQ PAGE

Type – Selectable band types provide even greater flexibility.

- **Shelving** – This type equally boosts or cuts all frequencies above or below the specified frequency, forming a “shelf.” The typical bass or treble controls of most devices are shelving EQs.
- **Shelving 2** – A “Passive EQ” type, with the “overshoot” you’d expect from a vintage EQ.
- **Peaking** – A peak filter cuts or boosts around a center frequency.
- **Peaking 2** – In comparison, this variant responds differently to low Q settings.
- **Low-Blocking** – The blocking filter only allows frequencies above the cutoff frequency to pass.
- **High-Blocking** – The blocking filter only allows frequencies below the cutoff frequency to pass.

Frequency – Sets the center or cutoff frequency for the selected band.

Q – This sets the filter bandwidth around the center or cutoff frequency. Set Q low for a broad, gently-sloping boost/cut, or set high for a narrow, sharp boost/cut.

Three examples below demonstrate different Q values for a “Peaking” band. No values are changed except Q.

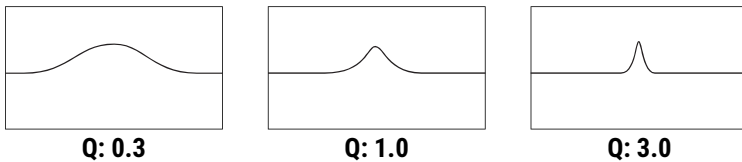

Gain/Slope – Sets the strength of the effect for a band from -12 to +12 dB. If the outer bands are set to “Blocking” this becomes a Slope control, with options from 6–36 dB per octave.

Solo – Isolates or “solos” the designated band so you can focus on its role within the overall sound.

MIX PAGE

The Parametric Equalizer block has **Level**, **Balance**, **Bypass**, and **Bypass Mode** parameters. See [“Common Mix/Level Parameters” on p. 7.](#)

FAQ: HOW SHOULD I EQ? Equalization can be as intricate an art as musicianship itself. Engineers, producers and artists use EQs to compliment, correct, and even create. The following simple tips will help you use EQ blocks to their fullest.

1. EQ works completely differently *before* distortion vs. *after* distortion. Try it each way. Try both at once!
2. If you hear something you don’t like (such as “boom” “honk” or “fizz”) use EQ to cut it. If you need help finding the frequency to cut, try boosting first, then sweep around until you find the objectionable area. Turn your boost into a cut and fine tune. Experiment with shelving, blocking or peaking types for this application.
3. If a sound seems to be missing something, try adding it in with an EQ boost. You can use the same “sweeping” technique described above, but remember, “you can’t put back what isn’t there,” meaning that a change to some other aspect of the tone (amp? cab?) may be needed to achieve what you’re after...
4. EQ in context and at appropriate volume levels. See your **Owner’s Manual** for more on setting levels.

THE PHASER BLOCK

PHA

The Phaser or Phase Shifter uses a series of all-pass filters with a feedback circuit to create a unique effect. Phase cancellation and reinforcement is used to create notches and peaks, and when these are shifted with an LFO, the distinctive swooshing sweep of the phaser created. Phaser effects can sound watery or airy. Unlike a chorus or flanger, there is no time/pitch modulation involved.

Examples of phasing include *The Atomic Punk* by Van Halen, *Hole in my Life* by The Police, *Have a Cigar* by Pink Floyd, *Machine Gun* by Jimi Hendrix, *Pink Napkins* by Frank Zappa, and countless classic 1970s recordings on which phasers are used for both guitar and keyboards, especially electric piano and clavinet.

The Phaser block allows from 2 to 12 stages to be cascaded for subtle or extreme phasing, with positive or negative feedback options offering distinctly different sounds. A flexible, stereo LFO can imitate the classics or provide new modulation possibilities not possible on any vintage phaser. The phaser even includes a special mode based on the Shin-ei™ Uni-vibe™ effect. The phaser block is stereo in, stereo out.

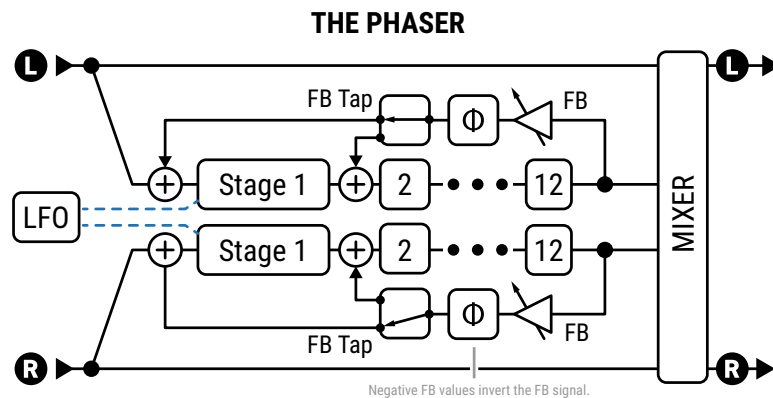

PHASER PARAMETERS

Type – Sets other parameters for different useful sound settings. Types include: **Digital Mono, Digital Stereo, Script 45, Script 90, Block 90, Classic Vibe, Stereo 8-Stage, Barberpole, Stripe 90, Naughty Rock, FAS Vibe, Treadle Phaser, Virtuoso Phaser, Borg Phaser, Ultra-Super-Mega Phaser, and Mutated Twin-Phaser.**

“Vibe” modes are based on a Uni-vibe™ effect, while the “Barberpole” type creates a sound evocative of a “Shepard” tone.

Rate – Sets the frequency of the LFO (“Low Frequency Oscillator”) that creates the sweep. When shown in parentheses, Rate is being controlled by the **Tempo** parameter (see below). Set Tempo to “NONE” for manual control. Set fully counterclockwise to sync to the **LFO1** controller source (see your **Owner’s Manual**).

Tempo – Synchronizes the rate of the Phaser LFO in rhythmic relation to the Tempo. For example, if the Tempo is 120 BPM, and Tempo is set to a “1/4,” the LFO rate will be 2 Hz (120 BPM / 60 seconds = 2).

Depth – Set higher for more dramatic phasing effects. Set to 0 for manual control.

Feedback – Feedback, known on some phasers as “regeneration” or “resonance,” controls how pronounced the peaks and notches are. This control is largely responsible for the iconic sound we associate with a Phaser.

Manual – Manually sweeps the phaser from the lowest to the highest point of its cycle. When **Depth** is at minimum the phaser is controlled entirely by Manual. When Depth at maximum the frequency is controlled solely by the LFO.

Tone – A simple tone control (wet only).

FRACTAL AUDIO BLOCKS GUIDE

Order – Sets the number of phase shifting circuits—or “stages”—in increments of two. Different settings sound distinctly different. For a more pronounced effect, increase the order.

Feedback Point – This directs feedback to any point in the phase shifter chain. A value of ‘0’ indicates prior to the beginning of the phase shifter chain. A value of ‘1’ indicates the first stage and so on. Both positive and negative values of feedback are allowed. When adding feedback experiment with the Mix value. Increasing the Mix can achieve rich, hybrid vibrato/phase sounds.

Minimum Frequency, Maximum Frequency – These set the potential range of the sweep of the phase shifter, from its lowest to its highest sweep. These settings update automatically when the **Type** is changed.

LFO Type – Selects the “shape” of the LFO, determining how the sweep changes over time.

LFO Phase – Sets the phase difference of the right waveform of the Phaser LFO. Values greater than 0° produce stereo phasing. A setting of 180° reproduces the legendary “reverse sync” setting of the classic 70s “Bi-Phase” (which incidentally was a 6th order phaser in this mode).

LFO Quantize – This control allows “stepped” effects in which the smooth shape of the LFO is transformed into a series of flat stages similar to those heard when a “sample and hold” technique is used.

Astable Beta – This changes the contour of the waveform when the LFO shape is set to Astable. At low settings, the waveform is similar to Triangle. At high settings, it resembles a half-lazy Square.

LFO Hicut – Lowering this control filters the LFO waveform, rounding the edges of sharp turns in its shape. The highest setting of 100Hz is basically unfiltered. Certain waveform types (saw, square, random) can otherwise cause clicks or pops as their values jump from one extreme to another. When you adjust **Rate**, you may need to re-visit this setting. A slower LFO needs a lower Hicut setting to preserve the same effect.

VCR Type – No, this parameter will not simulate recording your favorite TV shows. Instead, VCR in this case stands for “Voltage Controlled Resistor,” a component used in the circuit of the analog phaser. The different types are used to recreate different phaser circuit designs. “LINEAR” is a simple linear mapping of LFO voltage to frequency. “EXPONENTIAL” can be more “musical” because of the way frequencies are perceived. “JFET” types are commonly used in phaser pedals. “PHOTOCELL” simulates the response of CdS or Vactrol type components.

VCR Bias – Controls the bias point of the virtual VCR. A value of zero biases the VCR optimally. Negative values result in the VCR entering cutoff (infinite resistance).

The following parameters allow you to fine tune the different VCR Types:

Exponent controls the EXPONENTIAL type. A value of 1.0 is “ideal” and results in the notches sweeping linearly with log(frequency). Higher values cause the frequency to dwell at higher frequencies and then decrease rapidly towards the lower frequencies. Lower values cause the frequency to dwell at lower frequencies.

Photocell Attack and **Photocell Release** shape the response of the PHOTOCELL type. Typical photocells used in phasers have an attack time of 5 ms and a release time of 35 ms but there is a bit of variation between photocell types. Shorter release times result in a “lumpier” response.

LFO Reset on Bypass – Makes the phaser start from a fixed point in its sweep cycle when you engage the effect. With the default value of “OFF” the LFO will cycle freely, even when the effect is off.

Sweep Direction – Unique to the Barberpole type, this determines whether the sweep is up or down.

Filter Q – Unique to the Barberpole type. Together with **Feedback**, it controls the intensity of the effect.

MIX PARAMETERS

The Phaser block also has **Mix**, **Level**, **Balance**, **Bypass**, **Bypass Mode** and **Global Mix** parameters. See [“Common Mix/Level Parameters” on p. 7.](#)

THE PITCH BLOCK

PIT

The Pitch block uses our latest high-speed pitch detection and incredibly smooth shifting to produce a great range of different effects.

Octave Divider effects add one or two voices down. They have been around since before the dawn of digital.

Detune effects use micro-shifts to create chorus or double-tracked sounds.

Fixed pitch shifters allow you to add parallel harmonies or transpose without using a capo (“polyphonic shifting”).

Intelligent shifters create scale-based harmonies, where each shifted note is drawn from a given scale/key (with options for both traditional and custom scales).

Whammy effects are designed to be controlled by an expression pedal. Tom Morello with Rage Against the Machine helped put this type of effect on the map, and now it has become a staple, having been adopted by players from David Gilmour to Steve Vai to Jack White.

Crystal Echoes type uses forward or reverse granular time stretching to create their distinctive sound.

The **Virtual Capo** can be used to tune up or drop tune the entire guitar.

In the Pitch block, the types above are bolstered by various add-ons including multi-voice capability, built-in LFO modulation, stereo panning, EQ, delays, feedback, modifier control and more. In addition to the many new parameters and features of this block, the pitch detector is faster and more stable than ever before and can be even assigned to any input.

Because the Pitch block is larger with more types and more variations than most blocks, this section is divided as follows:

[“Pitch Block Types” on p. 64](#) provides an overview and covers similarities and differences between types.

[“Pitch Block Common Parameters” on p. 65](#) covers parameters that apply to multiple types.

Pages [p. 65](#) through [p. 72](#) cover the different types in detail.

PITCH BLOCK TYPES

Type – Make a selection using the **VALUE** or **NAV** buttons with no need to press **ENTER**.

Types are summarized below.

- **Dual Detune** and **Quad Detune** are used for chorus-type effects based on precision detuning of each voice. Both types include an LFO for modulation, and the Quad type also allows feedback.
- **Dual Shift**, **Quad Shift** and **Quad Shift Delay** provide a range of options including mono- or polyphonic shifts.
- **Dual Harmony** and **Quad Harmony** and **Quad Harmony Delay** provide diatonic or “intelligent” pitch shifting.
- **Classic Whammy** and **Advanced Whammy** are single-voice shifters intended for foot control.
- **Octave Divider** provides two voices for easy one and two octave shifts down.
- **Crystal Echoes** uses splice-based shifting to achieve an effect worthy of its name.
- **Arpeggiator** uses diatonic or “intelligent” pitch shifting with a 16-step sequencer to shift in melodic patterns.
- **Custom Shifter** works with global scales to specify a custom shift amount for each of the 12 chromatic tones.

PITCH TYPES COMPARISON TABLE

Type	Voices	Detune per Voice	Shift per Voice	Delay per Voice	Feedback
Dual Detune	2	±50 cents +LFO	No	0–250 ms	None
Quad Detune	4	±50 cents +LFO	No	0–250 ms	Shift Inside
Dual Shift	2	±50 cents +LFO	±24 semitones	0–2000 ms	Shift Inside
Quad Shift	4	±50 cents +LFO	±24 semitones	0–2000 ms	None
Quad Shift Delay	4	±50 cents +LFO	±24 semitones	0–2000 ms	After Shift
Dual Harmony	2	±50 cents +LFO	±25 Scale Degrees (Intelligent)	0–2000 ms	None
Quad Harmony	4	±50 cents +LFO	±25 Scale Degrees (Intelligent)	0–2000 ms	None
Quad Harmony Delay	4	±50 cents +LFO	±25 Scale Degrees (Intelligent)	0–2000 ms	After Shift
Custom Shift	2	±50 cents, NO LFO	±24 semitones (Intelligent)	0–2000 ms	None
Arpeggiator	1	None	±24 Scale Degrees (Intelligent)	None	--
Classic Whammy	1	None	±1–2 octaves	None	--
Advanced Whammy	1	None	±24 semitones	None	--
Octave Divider	2	None	–1 and –2 octaves	None	--
Crystal Echoes	2	±50 cents, NO LFO	±24 semitones	0–2000 ms	Shift Inside
Virtual Capo	1	±50 cents, NO LFO	±24 semitones	None	None

Note: The table refers to two different feedback types used by the Pitch block: **Shift Inside Feedback** and **Feedback After Shift**. With the pitch shift *inside* the feedback loop of the delay, each repeat is shifted again, so the pitch gets higher and higher or lower and lower over time. With the feedback return point after the pitch shift, each echo sounds the same: an identical copy of the original shifted signal. This difference is illustrated below:

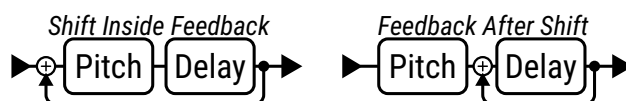

Pitch Block Common Parameters

The following are shared by multiple types within the Pitch block. Any key exceptions are noted below.

CONFIG PAGE

Input Mode – The Pitch block normally sums input signals to mono before processing. All Detune and Shift types allow stereo pitch shifting:

- **Dual Detune, Dual Shift:** In Dual types, when **Input Mode** is set to “STEREO”, the left input signal is routed to voice 1 and the right is routed to voice 2.
- **Quad Detune, Quad Shift, Quad Shift Delay:** In Quad types, when **Input Mode** is set to “STEREO”, the left input signal is routed to voices 1+3 and the right is routed to voice 2+4.

LFO Rate, LFO Tempo, LFO Depth – Most Pitch types with detune also have an LFO to modulate the detune. Use these controls to add a chorus or vibrato effect. LFO Rate sets the speed of modulation and can be set in rhythmic relation to the tempo using LFO Tempo (set to “NONE” for manual control). LFO Depth sets the range of pitch modulation. Modulation phase is varied by 90° from voice to voice (0°, 90°, 180°, 270°).

MASTER PARAMETERS

Master Level – Scales the output levels of all voices.

Master Pan – Scales all voice pan amounts, essentially acting as a “width” or “spread” control. Negative values reverse pan positions in left and right channels.

Master Feedback – Scales the feedback settings for all voice delay lines.

Master Pitch – Scales shift amounts for all voices. Does *not* scale detune values.

Master Delay – Scales **Delay Time** amounts for all voices.

DETECTOR PARAMETERS

Detector Source – This allows you to select a source for the shifter to use in pitch calculations. Detune and Crystal types do not use the detector.

- **Block In** – Pitch information is detected and analyzed at the input of the Pitch block. This mode allows the detector to track the pitch of a delay or effect tail even after you’ve stopped playing. This mode also considers the internal feedback of the Pitch block when calculating pitch.
- **Input 1/2/3/4** – In this mode, the pitch information comes from the signal at the designated input. This is unaffected by other effects in the current preset and can be an excellent choice for single note tracking.

Pitch Tracking – Selects between FAST and SMOOTH modes. You can also turn tracking “OFF” for vintage-style “fixed” shifting.

Tracking – This control allows fine-tuning of the pitch shifter “splice length.” For large shifts, adjustments can help improve the quality of the shifted note.

Temperament – Switches between “Equal” and “Just” temperaments. Just temperament, while technically slightly out of tune compared to the fretted notes, uses “pure” ratios defined by the harmonic overtone series and can be used for “sweeter” harmonies, especially when followed by distortion.

Dual Detune, Quad Detune

FRACTAL AUDIO BLOCKS GUIDE

Two different detune algorithms effects provide rich doubling and chorus-like effects, and more.

THE QUAD DETUNE

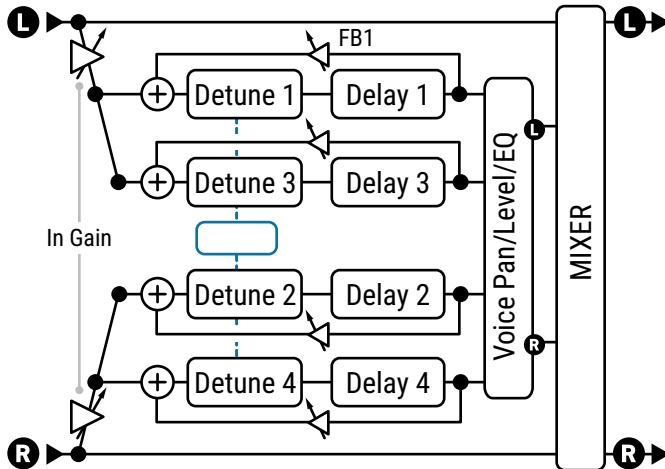

The four-voice **Quad Detune** is shown here. In comparison, the **Dual Detune** has only two voices and no feedback. Both types have stereo input modes (as shown here) or can sum left and right input signals to mono before processing. Quad Detune feedback wraps around the detuners.



Detune 1,2,3,4 – These set the detune amount for each voice ± 50 cents.

Delay 1, 2, 3, 4 – These set the delay time of the selected voice from 0–250 ms.

Feedback Mode – (Quad Detune only) Sets whether feedback is “INDIVIDUAL” for each voice (as shown above) or “SUMMED”, which sends the summed output of all four voices to the input of every voice.

WARNING! Summed feedback can quickly get out of control. Reduce Feedback before changing the mode.

Feedback 1, 2, 3, 4 – (Quad Detune only) These set the feedback amounts for each voice. Feedback can be used for beautiful flanger effects or create cascading spirals bordering on the deranged.

Level 1, 2, 3, 4 – These set the volume level of each voice.

Pan 1, 2, 3, 4 – These set the pan position for each voice.

Master, LFO, and Mix parameters for the Detune types are covered under [“Pitch Block Common Parameters” on p. 65](#).

Dual Shift, Quad Shift, Quad Shift Delay

Three different algorithms effects provide fixed shifting effects.

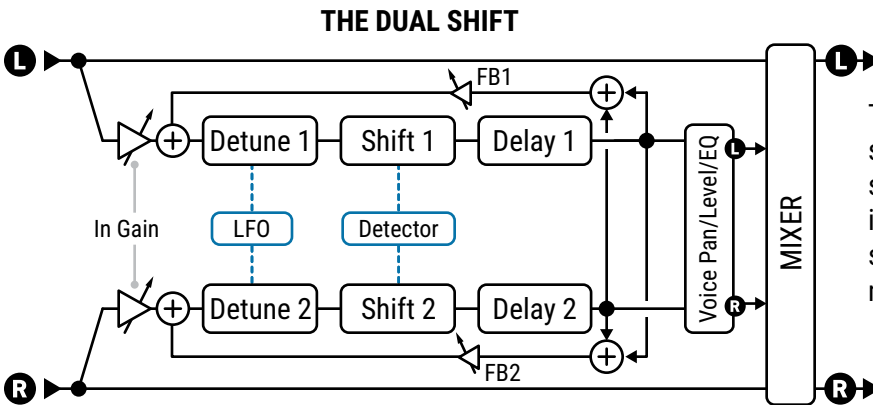

The two-voice **Dual Shift** is shown here. The Detector input is selectable. The stereo input mode is shown here. Mono input mode sums left and right input signals to mono before processing.

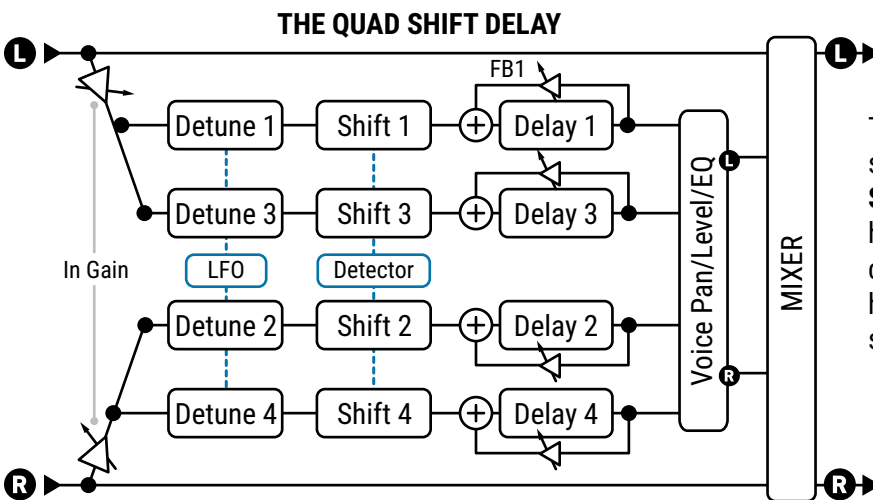

The four-voice **Quad Shift Delay** is shown here. In comparison, the **Quad Shift** has no feedback. Both types have selectable Detector inputs and can use stereo input modes (as shown here) or can sum left and right input signals to mono before processing.

Detune 1,2,3,4 – These set the detune amount for each voice from ± 50 cents.

Shift 1,2,3,4 – These set the shift amount for each voice ± 24 semitones.

Delay 1,2,3,4 – These set the time for the corresponding voice from 0-2000 ms. When shown in parentheses, it is being set automatically by the corresponding **Tempo** parameter (see below). Set Tempo to “NONE” for manual control.

Delay Tempo 1,2,3,4 – These set the corresponding **Delay** time parameter in rhythmic relation to the Tempo.

Feedback 1, 2, 3, 4 – These set the feedback amounts for each voice. In the **Dual Shift**, the feedback return is *before* the shifters, so successive repeats continue to get higher or lower in pitch. Feedback is also summed, so each voice crosses over to the feedback of the other. The **Quad Shift** has no feedback. In the **Quad Shift Delay**, the feedback return is after the shifters, so successive repeats do not change in pitch. Feedback is per-voice so voices do not cross over in the feedback tail.

Level 1, 2, 3, 4 – These set the volume level of each voice.

Pan 1, 2, 3, 4 – These set the pan position for each voice.

Master, LFO, and Mix parameters for the Shift types are covered under [“Pitch Block Common Parameters” on p. 65](#).

Harmony (Dual, Quad, Quad Delay)

In comparison to **Shift** types, the Harmony types use a **Key** and **Scale** to determine the amount of shift. Three different algorithms provide three different variations of this effect. Structurally, they are all very similar to the **Quad Shift Delay** (pictured on [p. 67](#)) in that the shifted voices are mixed in parallel to the dry signal, with detune and delay on every voice. Only the **Quad Shift Harmony** type has feedback parameters, with the return located after the shifter so successive repeats are NOT shifted again and again.

The following unique parameters are used for the Harmony shifters:



Key – Sets the key for the harmony.

Scale – Sets the scale or mode into which notes will be shifted. A table of **Scale Types** is provided on [p. 70](#).

Learn – While learn is “ON”, the **Key** parameter will automatically change to whatever single note you play. Assign to a footswitch for key changes right in the middle of a phrase! Turn this “OFF” again to return to normal harmonizer function.

Harmony 1,2,3,4 – These set the scale degree that each voice will sound.

It is important to recognize that this is NOT a “semitones” control as used in the **Shift** types, but a specification of which note in the scale should be used. To hear how it works, or to audition any scale, set the **Key** to “G,” play the open G string and change the **Harmony** value.

If the current scale contains more or less than seven notes, not including the tonic, (diminished, whole tone, custom, etc.), you may need to use your ears or do a bit of math to identify how its degrees play out over multiple octaves.

Glide Time – sets the rate at which the harmony shifts from the one pitch to another as different notes are played.

CUSTOM SCALE PARAMETERS

Each of the **Harmony** types provide a set of parameters for creating a basic custom scale of up to eight notes. In comparison, the **Custom Shift** type (page [p. 72](#)) provides a more extensive way to dial in custom harmonies with up to 12 defined notes.

To use the custom scale, first set the **Scale** parameter (above) to “CUSTOM”.

Number of Notes – Sets the number of notes in your custom scale from four to eight.

Tonic – This parameter has no effect on how the scale will sound in actual use but instead allows you to see an example of your custom scale transposed to any key. Change this to whatever makes it easiest for you to dial in the custom notes. Remember: what matters when dialing in a scale is the intervals between the notes.

Note 1,2,3...8 – These are the notes of your custom scale relative to the TONIC. Set to define the scale degrees. Each scale degree must be at least ½ step higher than the previous.

Arpeggiator

The Arpeggiator uses a 16-step sequencer to control the shift amount of a harmonizer so that complex melodic patterns can be created from a single note. This is an “intelligent” shifter which works within a designated key/ scale as you play different notes. So, in the key of C (Ionian) Major, the note “C natural” will arpeggiate as C-E-G (C major), but the note D natural will arpeggiate as D-F-A (d minor)

The Arpeggiator parameters are identical to those of the Harmony types (previous page) except as noted below. The Arpeggio type has no feedback parameters.

Key – Sets the key for the arpeggios.

Scale – Sets the scale or mode into which notes will be shifted. A table of **Scale Types** is provided on [p. 70](#).

Arpeggiator Run – When set to “ON,” the sequence starts. When set to “OFF,” the sequence stops and resets to the beginning. Attach the Envelope Follower (p xx) to re-trigger the sequence on each new note.

Arpeggiator Steps – Sets the number of steps in the pitch sequencer.

Arpeggiator Repeats – Sets the number of times the sequence will repeat once triggered. Set to “INFINITE” to loop.

Arpeggiator Tempo – Sets the duration of each sequencer step as a rhythmic value in relation to the Tempo.

Amplitude Shape, Pan Shape – Specifies how the volume or pan changes as the arpeggiator cycles.

Amplitude Alpha, Pan Alpha – Sets the acceleration of the rate of volume or pan change. A setting of 0% results in no effect, while 100% results in an extreme effect.

Stage 1, 2, 3... 16 Shift – These set the number of scale degrees that each note of the arpeggiator will be shifted above or below the note played.

Let’s look at the example of a four-stage arpeggio with values of 0, 2, 4, and 7.

We’ll set Key to C and Scale to Major (Ionian). When we play a C, the arpeggiator will play C-E-G-C’, because:

- C + 0 scale degrees = **C**
- C + 2 scale degrees = **E** (C...D, E)
- C + 4 scale degrees = **G** (C...D, E, F, G)
- C + 7 scale degrees = **C’** (C...D, E, F, G, A, B, C’)

If we play a D, the arpeggiator will play D-F-A-D’, because:

- D + 0 scale degrees = **D**
- D + 2 scale degrees = **F** (D...E, F)
- D + 4 scale degrees = **A** (D...E, F, G, A)
- D + 7 scale degrees = **D’** (D...E, F, G, A, B, C’, D’)

Remember that the notes of the arpeggios and the steps required to arrive at them are drawn only from the designated **Key** and **Scale**. So in the example above, **C** produced a **C major** arpeggio and **D** produced a **D minor** arpeggio: both naturally occurring in the key of C major.

Scales with more or fewer than seven notes in one octave (diminished, whole tone, custom, etc.) can require some mental math, and it is sometimes easiest to just use your ears.

Tip: By choosing the **CHROMATIC** scale, you can create a pattern that ignores the notes you play and simply shifts pitch by a specified number of semitones.

SCALE TYPES AND FORMULAS

Here is a set of scale formulas for all scales used in the **Harmony** and **Arpeggiator** pitch types. If scale names or formulas look slightly different from what you've learned, remember this joke:

Q: How many musicians does it take to describe a scale?

A: Well, let's see there's Bird, Yardbird, Zoizeau, Charlie, Satchmo, Pops, Satchel Mouth, Dipper Mouth, Louis... so that's TWO right there..."

Scale Name	1	2	3	4	5	6	7	8
IONIAN (MAJOR)	1	2	3	4	5	6	7	
DORIAN	1	2	b3	4	5	6	b7	
PHRYGIAN	1	b2	b3	4	5	b6	b7	
LYDIAN	1	2	3	#4	5	6	7	
MIXOLYDIAN	1	2	3	4	5	6	b7	
AEOLIAN (MINOR)	1	2	b3	4	5	b6	b7	
LOCRIAN	1	b2	b3	4	b5	b6	b7	
MELODIC MINOR	1	2	b3	4	5	6	7	
HARMONIC MINOR	1	2	b3	4	5	b6	7	
DIMINISHED (whole-half)	1	2	b3	4	b5	b6	b6	7
WHOLE TONE	1	2	3	#4	#5	b7		
DOMINANT 7 (aka dim. half-whole)	1	b2	#2	3	#4	5	6	b7
DIMINISHED/WHOLETONE	1	b2	#2	3	#4	#5	b7	
PENTATONIC MAJOR	1	2	3	5	6			
PENTATONIC MINOR	1	b3	4	5	b7			
BLUES	1	b3	4	b5	5	b7		
CHROMATIC	All 12 tones							

Octave Divider

The Octave Divider simulates the classic analog effect which turns the input into a square wave and then lowers the frequency using a "flip-flop" circuit. Like the classic effect, this effect really only works as intended with single notes and would usually be placed before distortion.

Voice 1 and Voice 2 are fixed at one and two octaves down. Each has its own Pan and Level controls.

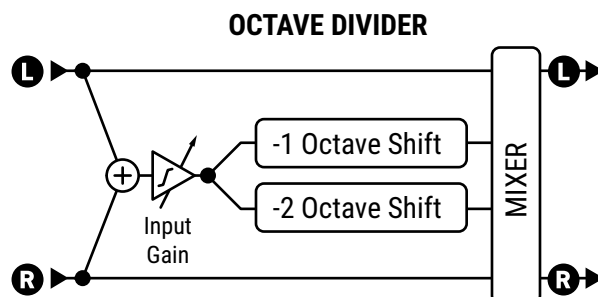

Whammy (Classic + Advanced)

The whammy effect, first introduced in 1991, is a relative newcomer to the field of guitar effects. The Classic Whammy brings all of the traditional sounds of this pedal. Its **Whammy Control** parameter can be operated remotely using a modifier like a pedal (though don't let this convention limit your creativity; sequencer and LFO pitch effects can be great too, as demonstrated in *Map of the Problematique* by Muse).

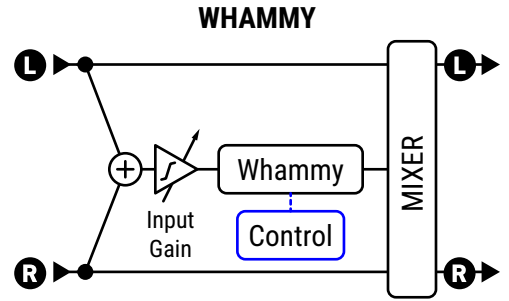

Whammy Mode – The **Classic Whammy** uses a single parameter to select between the following shift options:

- Up 1 Octave
- Down 1 Octave
- Up 2 Octaves
- Down 2 Octaves
- Up 1 Octave, Down 1 Octave
- Up 2 Octaves, Down 2 Octaves

Start Shift, Stop Shift – The **Advanced Whammy** type uses two parameters to specify the shift in semitones. This allows you to customize the range for effects such as whole-step “bender”, 4th down/5th up, or anything else you can imagine within a range of ±24 semitones.

Whammy Control – This controls the whammy and would normally be assigned to a pedal, switch, or some other controller using a modifier.

Tracking Mode – Use this to optimize the pitch shifter for tracking single notes (“MONO”) or chords (“POLY”). You can also turn tracking “OFF” for vintage-style “fixed” shifting.

FAQ:

WHAT ABOUT DROP TUNING? Drop tuning pedals use polyphonic pitch shifting to simulate the sound of a lowered guitar tuning. The **Advanced Whammy** is perfect for this type of effect. Place it at the beginning of your signal path, prior to any Drive or Amp blocks. To make setup easy, just RESET the desired pitch block channel and then re-select the **Advanced Whammy** type. Dial in the drop tune with just a few simple changes. The most important setting is found on the **Mix** page. Set the **Mix** parameter to 100% so that only the “wet” portion of the effect is heard. Also check that **Tracking Mode** is set to “POLY” and **Whammy Control** is at 100%. For the drop, set **Stop Shift** to the desired value. (Ideally, you should have If you have a modifier on **Whammy Control**, perhaps for use in a different channel, just set **Start Shift** to match the value for **Stop Shift**.)

Key	Shift
E _b /D _#	-1
D	-2
D _b /C _#	-3
C	-4
B	-5
B _b /A _#	-6
A	-7
A _b /G _#	-8
G	-9
G _b /F _#	-10
F	-11
E	Srsly?

Assuming you are in standard “E” tuning, a table of drop values you can use for any tuning is shown here. Of course, you can also use this effect for “up tuning” effects. As with any tuning effect, the farther you shift in either direction, the less natural it sounds.

Virtual Capo

The Virtual Capo type is a one voice shifter that can be used to tune up or drop tune the entire guitar. Its controls are very simple. When you select this type, the mix is set automatically to 100% wet.

Shift controls the amount of shift, up to 2 octaves up or down in semitones (aka *half steps* i.e. *number of frets*)

Detune adds an additional slight shift in cents (each cent is 1/100th of a semitone).

📁 MIX PAGE

The Pitch block has **Mix, Level, Balance, Bypass, Bypass Mode, Input Gain** and **Global Mix** parameters. See [“Common Mix/Level Parameters” on p. 7.](#)

Low Cut, High Cut – These filter the wet signal only, gently rolling off lows or highs with a slope of 6db.

THE PLEX DELAY BLOCK

PLX

The Plex Delay block uses a feedback matrix so that each of multiple delay lines is fed back to itself and all the others. The effect can produce very smooth, reverb-like atmospheric effects. When combined with modulation or detune, the result is a huge and lush-sounding space with qualities of echo, reverb, and chorus all at once.

In comparison to other Plex effects, the Plex Delay block allows the use of 4, 6 or 8 delay lines at once.

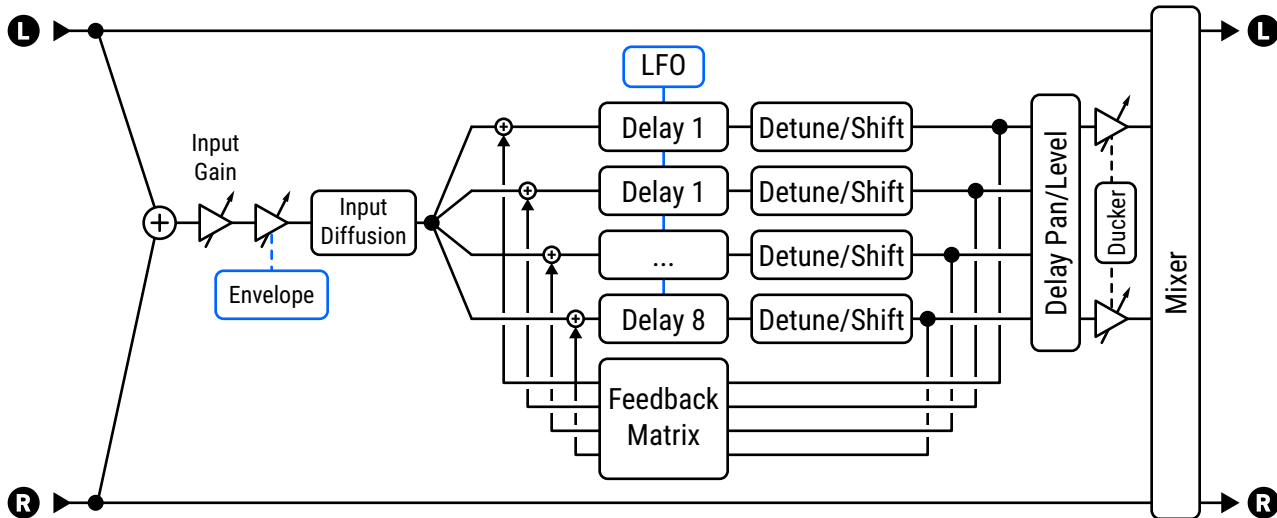

This diagram shows Plex Shifter. Plex Detune lacks "Shift" parameters. Plex Delay has no pitch effects.

TYPE PAGE

Type – Make a selection using the **VALUE** or **NAV** buttons with no need to press **ENTER**.

- **Plex Delay** is the most basic type of this algorithm, with up to eight lines, delay modulation, input diffusion, built-in ducking, input envelope controls, and more.
- **Plex Detune** is based on Plex Delay, but adds eight high-quality pitch shifters with a range of ± 50 cents to the output of the delay taps. These create a chorusing effect in the plex tail.
- **Plex Shifter** adds eight high-quality pitch shifters with a range of ± 24 semitones for everything from angelic shimmers above, to infrasonic depths below.
- **Plex Verb** creates large, lush, spacious, ethereal reverbs with a minimum of parameters.
- **Shimmer Verb** creates classic shimmer effects with scintillating upper octaves.

CONFIG PAGE

Plex Delay and Common Parameters

CONFIG PAGE: CONFIGURATION SECTION

Number of Delays – Sets the number of delay times in the matrix. Higher values increase the density of the effect but also use slightly more CPU. Note that other parameters will always be shown in sets of eight, even when Number of Delays is set lower.

Decay Time – Adjusts the feedback matrix to control the time required for echoes to fade. Use caution, as high decay times can result in instability.

Diffusion – This is “the” plex effect, determining how much cross-feedback there is between delay lines. This contributes to the density or smoothness of the effect.

Low Cut, High Cut – These set the cutoff frequencies for gentle high- and low-pass filters in the feedback matrix.

Pre-Delay – Adds extra delay before the plex effect is heard.

Stack/Hold – Use this for infinite playback of the Plex delay “tail”. Setting the switch to HOLD defeats the inputs and causes the current tail to continue indefinitely. The STACK option holds the tail but leaves the input open so you can layer additional material while it continue.

CONFIG PAGE: FILTER SECTION

Type, Frequency, Q, Gain – These control a filter on the “wet” signal of the Plex delay. These controls operate as you would expect (Filter block [p. 39](#)) and also allow modifiers for dynamic effects.

CONFIG PAGE: MASTERS SECTION

Master Time – Scales all of the delay times in the block.

Master Level – Scales the output levels all of the delay times in the block.

Master Pan – Scales all pan values, essentially acting as a width or spread control. Negative values reverse left and right channels.

CONFIG PAGE: TIME AND TEMPO SECTIONS

Delay Time 1–8 – These set the times for the eight delay lines. If a tempo value appears in (parentheses) this indicates that the corresponding delay has a **Tempo** value set and cannot be changed manually.

Tempo 1–8 – These set the tempo for the eight delay lines.

CONFIG PAGE: LEVEL AND PAN SECTIONS

Level 1–8 – These set the levels for the eight delay lines.

Pan 1–8 – These set the pans for the eight delay lines.

CONFIG PAGE: ENVELOPE FOLLOWER SECTION

Plex delays are frequently used after a volume pedal or envelope for “swells” of ambient sound. The Plex Delay block has a built-in **input envelope follower** which controls effect send levels *inside* the block.

Threshold, Attack, Release – These set the threshold level and times for the input envelope. Tip: For a basic volume “roll up” setting, try Threshold: -70.0 dB; Attack: About 400 ms; Release: about 15 ms.

Plex Detune Parameters

Plex Detune offers these additional parameters:

Granule Length – Sets the length in the granules of the pitch shifters. Lower settings give a “grainy” sound, while higher values have a smooth blended sound.

Detune 1–8 – Sets the amount of detune within a range of ± 50 cents. Small values create a subtle chorus, higher settings create descending or ascending cascades.

Master Detune – This scales the settings for the eight detune parameters.

Plex Shift Parameters

Plex Shift offers these additional parameters:

Direction – Determines whether “granules” of audio in the pitch shifter are played back forward or reversed. To understand how this works, imagine a word whose individual letters have been mirror-imaged but are still in the correct left-to-right order (“Fractal” vs. “rɹɹɹɹɹɹ”). In this case, the letters are very short snippets of audio. These are reversed (and possibly pitch-shifted) but are played back in the order in which they were recorded. The length of the snippets for a given delay line depends on its **Time** setting.

Shift 1–8 – Sets the amount of detune within a range of ± 24 semitones. This is where “Shimmer” is born.

Plex Verb Parameters

Plex Verb offers the following additional parameters:

Reverb Size – This controls the length of time it takes for an echo to bounce between virtual surfaces.

Decay Time – Sets the decay time. This is the amount of time it takes for the reverb to vanish beyond the point of perception.

Shimmer Verb Parameters

Shimmer Verb is similar to the Plex Verb above, but has the following additional controls:

Shimmer Intensity – Selects between ten different levels of pitch shift intensity, adding upper octaves.

Crossfade/Direction – These set how pitch is processed inside the shimmer block. Higher crossfade settings smooth the shimmer sound. (Adding **Diffusion Mix** will smooth things even further.)

MODULATION PAGE

Ducker Attenuation – Sets how much the ducker reduces delay levels. A setting of 20 dB will decrease the echoes by 20 dB when the input level is above the threshold. Set to “0” to defeat the ducker.

Ducker Threshold – Sets the trigger level of the ducker. If the input signal exceeds this value, the delayed signal will be reduced by the amount set with the **Attenuation** control.

Ducker Release Time – Sets how long it takes for the delay signal to return to normal after the signal level drops below the threshold. A short value here will cause the ducked echoes to return to full volume the moment you stop playing. Longer times will cause the level to swell back gradually.

Input Diffusion, Diffusion Time – These set the level and time of an input diffuser, which adds a reverb-like effect to signals prior to the Plex, thickening effect tails and smearing transients to reduce the prevalence of individual echoes.

LFO Depth, LFO Rate – These set the depth and rate of modulation, which adds a chorusing effect.

LFO Tempo – Synchronizes the rate of LFO modulation to the tempo.

MIX PAGE

This block has **Mix, Level, Balance, Bypass, Bypass Mode, Input Gain** and **Global Mix** parameters.

See [“Common Mix/Level Parameters” on p. 7](#).

Stereo Spread – Controls stereo width by setting the pan position of the effect from hard-panned (100%) to dead mono (0%) – and beyond, with psychoacoustic effects increasing the apparent width from -200% to $+200\%$.

THE REALTIME ANALYZER BLOCK

Axe-Fx III Only **RTA**

The Realtime Analyzer block is an animated high-resolution multiband spectrum analyzer with parametric control. You can “set-it-and-forget-it” or adjust parameters to match your specific needs. You can tap grid signal anywhere to feed the RTA, allowing you to observe the frequency content.

CONFIG PAGE

Decay Time – Sets the decay or release time. The higher this value, the slowly each measurement will “fall off” in the display.

Input Select – Selects how the RTA handles incoming stereo signals. monitor left or right channels individually, or sum them together.

Bands – Sets the resolution of the display to 32, 64 or 128 bands.

Window Type – Selects between different window functions to determine how data is displayed. If you are not familiar “analyzer windowing”, you easily find more information online.

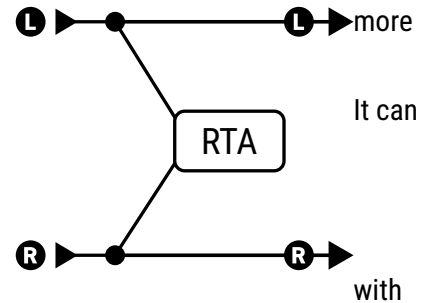

The RTA block has no channels and cannot be bypassed. Any signal at the block input is passed unmodified to the block output. In other words, sonically, it behaves exactly as a shunt.

THE RESONATOR BLOCK

RES

The Resonator uses four parallel delays with feedback to create resonant comb filters. By tuning the resonant frequencies, chords and other interesting sounds can be created. It is useful for metallic droning effects, or for creating polyphonic harmony from non-melodic sources like percussion or speech. Because the delays can be extremely short, the resonator can also be used with a modifier on Master Frequency to create a “high flanger” effect. Four bandpass filters use the same frequencies as the delays. They are shown here in the “post” position but can also be used “pre”.

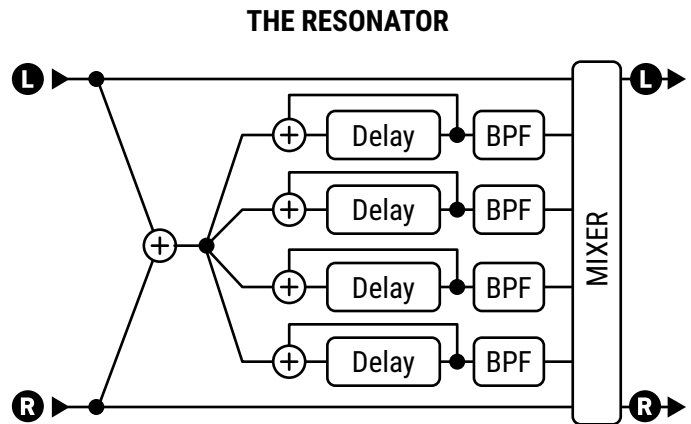

CONFIG PAGE PARAMETERS

Mode – The Resonator can operate in one of two modes.

- **MANUAL:** Resonator/filter frequencies are set individually as desired from 100–10,000 Hz.
- **CHORD:** Resonator/filter frequencies are set automatically based on a setting for the **Chord** parameter, which selects from various chord types (Major, Minor, etc.).

Master Freq/Frequency – In “MANUAL” Mode, this scales the frequencies set manually for the four resonators/filters. In “CHORD” Mode, this is replaced by **Frequency**, which sets the frequency for the chord root.

Master Level – Scales all the output levels.

Master Pan – Scales all the output pans. Use negative values to reverse the stereo image.

Master Feedback – Scales the feedback of all four resonators.

Master Q – Scales the Q of all four bandpass filters.

Input Mode – Selects between “MONO”, where left and right input signals are summed to all four resonators (as illustrated above) and “STEREO”, in which the left input channel feeds resonators 1+2 and the right feeds 3+4.

Frequency 1–4 – Sets the resonant frequency of the corresponding filter.

Feedback 1–4 – Sets the resonance of the corresponding filter by varying the feedback.

Filter Location 1–4 – Selects the position of the corresponding bandpass filter in relation to its resonator.

Filter Q 1–4 – Sets the Q of the corresponding bandpass filter.

Level 1–4 – Sets the output level of the corresponding resonator.

Pan 1–4 – Sets the pan position of the corresponding resonator.

MIX PAGE

The resonator block has **Mix, Level, Balance, Bypass, Bypass Mode, Input Gain** and **Global Mix** parameters. See [“Common Mix/Level Parameters” on p. 7](#)

THE REVERB BLOCK

REV

As an effect, reverb was one of the first. Since the dawn of music, musicians in small dead sounding places have wished they could hear the rich sounds their instruments make in a large reverberant spaces. Early simulators used metal tanks, springs or plates. Tube and solid state variants emerged, but reverb, like delay, was truly revolutionized by digital technology. Our latest reverb algorithm is at the leading edge of digital reverbs, and likely to be one of the finest you have ever experienced, with the ability to emulate real spaces, vintage plates and springs, classic digital effects, and more. The many “types” allow dialing in mix-ready sounds at the turn of a knob, while an extensive parameter list makes it easy to customize.

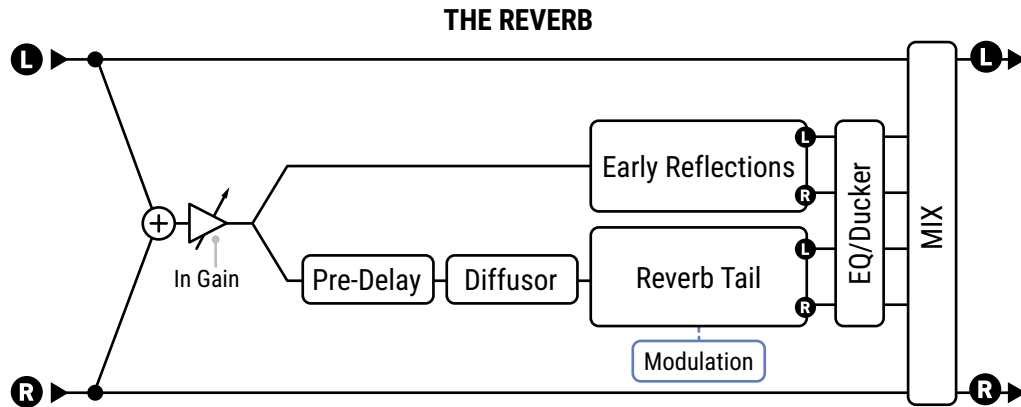

TYPE PAGE

Type – Make a selection using the **VALUE** or **NAV** buttons with no need to press **ENTER**. There are dozens of reverb types including Halls, Chambers, Rooms, Cathedrals, Studios, Plates, Springs, and many more.

BASIC PAGE PARAMETERS

Time – Sets the decay time. This is the amount of time it takes for the reverb to vanish beyond the point of perception. This is also known as the “t60” time, referring to the amount of time required for the reverb to decay to 0.001 of its initial value (-60 dB).

Predelay – Adds extra delay before the reverb starts. The **Size** control (see below) automatically imparts a certain amount of delay before the reverb starts. Use this control to add more delay if desired. For example, if the Size is low, the reverb will start almost immediately. You can use this control to add some delay before the reverb starts but keep the small-sounding size.

Size – Sets the size of the space or spring. This controls the length of time it takes for an echo to bounce between virtual surfaces. Higher settings increase the echo time and the delay before the reverb starts.

Large values can make the reverb more “grainy” as the time between the individual repeats increases. Lower settings smooth out the reverb, but very small values will create a metallic sound.

As the size increases, the reverb will become somewhat darker as more high frequencies are absorbed.

Mix and **Level** are duplicated from the MIX page.

Crossover Frequency, Low Frequency Time, High Frequency Time – The reverb algorithm is actually multi-band, reflecting the way that sound energy dissipates differently in real spaces. This allows for very natural effects. These parameters control decay times for the two bands, plus the crossover frequency.

Mod Depth, Mod Rate – These parameters controls modulation in the reverb tail for a dynamic effect similar to chorusing. Modulation helps fill out the soundstage and makes the reverb sound fuller. For non-pitched instruments like drums, modulation may be undesirable. (Set Depth to zero to defeat.) To dial in modulation, turn the Mix to max, adjust Depth and Rate, and then set the Mix as desired again.

EQ PAGE

Parameters on this page color the tone of the reverb but not the dry sound. Use these settings to change how the reverb sits in the mix of your overall sound, or to produce creative effects. An on-screen display shows the EQ curve as you adjust other parameters.

Low Cut, High Cut – These define high- and lowpass filters for broad EQ adjustments.

Low Mid Frequency, Low Mid Q, Low Mid Gain and **High Mid Frequency, High Mid Q, High Mid Gain** – A pair of 2-band peaking parametric EQs allow boosting or cutting at selected frequencies. Low Mid is lower range (20 Hz–2KHz) and High Mid is higher range (100 Hz–10KHz).

MIX PAGE

The Reverb block has **Mix, Level, Balance, Bypass, Bypass Mode, Input Gain**, and **Global Mix** parameters. See [“Common Mix/Level Parameters” on p. 7.](#)

The **Mix** page also contains the ducking controls. Ducking causes the “wet” level to be lowered automatically when the level of your playing goes above a set threshold. Then, when you play more quietly or pause, the effect volume increases so that the echoes fill the spaces.

Ducker Atten – Attenuation sets the amount by which the effect volume will duck (decrease). A setting of 20 dB, for example, will decrease the reverb by 20 dB when the input level is above the threshold. Set to 0 to defeat the ducker.

Ducker Threshold – Sets the trigger level of the ducker. If the input signal exceeds this value, the reverb signal will be reduced by the amount set with the **Attenuation** control.

Ducker Release – Sets how long it takes for the reverb signal to return to normal when the input goes back below the threshold. A short value here causes the ducked echoes to return to full volume very quickly. Longer times cause the levels to swell back more gradually.

“ALL” PARAMETERS PAGE

In addition to the parameters listed above, the **All** page includes the following parameters:

Early Level – Adjusts the relative level of the early reflections (has no effect for the “Spring” types.)

Late Level – Adjusts the relative level of the reverb tail.

Echo Density – Controls the density of the reverb tail. Higher values give a smoother sound. Lower values allow the individual repeats to be more easily discerned. This determines the overall smoothness of the tail. Large **Size** values will also make the individual echoes more apparent, as will lower settings for the various Diffusion parameters. For legato signals, lower values may be used. For short, percussive signals, a higher value may be more desirable as the reverb tail will more smoothly fill the “space”. This is a common parameter to lower to reduce CPU usage.

Early Diffusion – This sets the amount of diffusion in the early reflections. Higher values result in less distinct echoes. Lower values result in clear, distinct reflections.

Early Diffusion Time – This scales the delay time of the early reflection diffusers. Adjust this control to control the size and character of the simulated environment.

Early Decay – This parameter controls the decay rate of the early reflections. (Higher value = faster decay.)

Mic Spacing – Sets the stereo width of early reflections by simulating mic separation in the virtual space.

Late Input Mix – this routes the early reflections to the input of the late reverb “tail” generator. It uses a proprietary decorrelation technique which eliminates the metallic qualities common in other products.

Quality – Three options provide different ways to balance reverb complexity and CPU utilization. “NORMAL” provides excellent quality suitable for most guitar reverb needs, but conserves CPU power. “HIGH” provides an even smoother and more natural reverb at increased CPU cost, while ULTRA-HIGH takes this one step further. “ECONOMY” produces very good results at reduced CPU cost.

Repeat Stack/Hold – Use this to create “infinite” reverb. Setting the switch to HOLD defeats the inputs and causes the current tail to continue indefinitely. The STACK option holds the tail but leaves the input open so you can layer additional material while it continues.

Wall Diffusion – Controls how quickly the reverb tail’s density builds. Lower values makes discrete echoes last longer. Higher values cause the echo density to build rapidly for a more “washy” effect.

Input Diffusion, Diffusion Time– The reverb includes an additional diffuser at the input, which “smears” transients for a smoother overall effect. These parameters control the mix and time of this diffuser.

Stereo Spread – Controls stereo width by setting the pan position of the effect from hard-panned (100%) to dead mono (0%) – and beyond, with psychoacoustic effects increasing the apparent width from -200% to +200%.

SPRING PARAMETERS

The following three parameters only have an effect when one of the Spring reverbs is selected on the Type page.

Number Of Springs – This sets the number of springs. Using more springs produces a more dense reverb.

Spring Tone – This determines the tonal color of the virtual springs. Lower values create a darker tone.

Spring Drive – This allows overdriving the spring reverb circuit.

Boiiiiinnng! – This controls the “springiness” of the reverb.

ALL PAGE: MODULATION SECTION

Mod Depth, Mod Rate – These parameters controls modulation in the reverb tail, creating a rich chorus effect.

LFO Phase – Determines how modulation is applied to the right side of the reverb with respect to the left.

ALL PAGE: DUCKER SECTION

These parameters are covered under the **Mix Page** section (previous page.)

A WORD ON “SPILLOVER”

Like the delay, the Reverb block is capable of “spillover,” which means that effect tails ring out when the effect is bypassed or when you change scenes or presets. For more on Spillover, see your **Owner’s Manual**.

THE RING MODULATOR BLOCK

RNG

Ring Modulators are probably best-known for sci-fi synth and fusion electric piano sounds (or for Dalek/X-wing pilot voices), but they have been used to great effect on guitar as well. Check out the solo on *Paranoid* by Black Sabbath, *Satisfaction* by DEVO, or the *Blow by Blow* and *Wired* albums by Jeff Beck. A Ring Modulator uses fast changes in amplitude to create tones that are harmonically unrelated to the input. The Ring Modulator block goes beyond the classic effect in that the modulation frequency can track the pitch of the input signal for musically predictable results across the fingerboard.

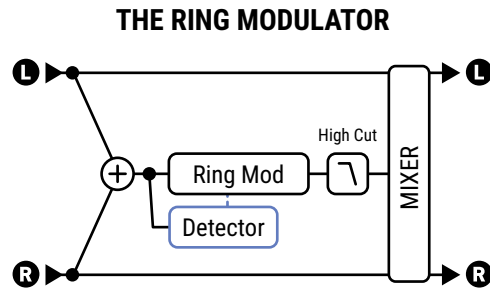

CONFIG PAGE PARAMETERS

Type – Selects between Classic and two different Single Sideband types.

Frequency – Sets the frequency of the oscillator used for amplitude modulation.

Frequency Multiplier – Scales the oscillator frequency from .25–4x.

Pitch Tracking – When this is set to “ON,” the frequency of the oscillator tracks the pitch of notes played at the input of the block, allowing for a completely different effect. The **Multiplier** is still applied, allowing for tones that range from very pure-sounding to totally exterminated.

Hi Cut Frequency – Reduce this value to filter highs from the Ring Modulator sound.

The Ring Modulator block also has the following Mix parameters: **Mix**, **Level**, **Balance**, **Bypass**, and **Bypass Mode**. See [“Common Mix/Level Parameters” on p. 7.](#)

THE ROTARY BLOCK

ROT

A Hammond B3 Organ without a Leslie cabinet is like a sandwich without bread. Guitar players also revel in the wonderful, spinning, 3D sound of the Leslie and its brethren. The classic unit contains a spinning slotted drum and a rotating horn called a rotor. A low-frequency speaker is aimed into the drum while high frequencies are sent to the spinning horn. The result is unmistakable: from schmaltzy hockey-game to Steppenwolf, the rotary is ubiquitous. Drum-only rotary speakers have also been produced, with Stevie Ray Vaughan's *Cold Shot* offering an example of this type of sound. The Rotary block reproduces all these classic sounds and offers more control. Also, it doesn't weigh 300 pounds and doesn't require four guys to move up a flight of stairs.

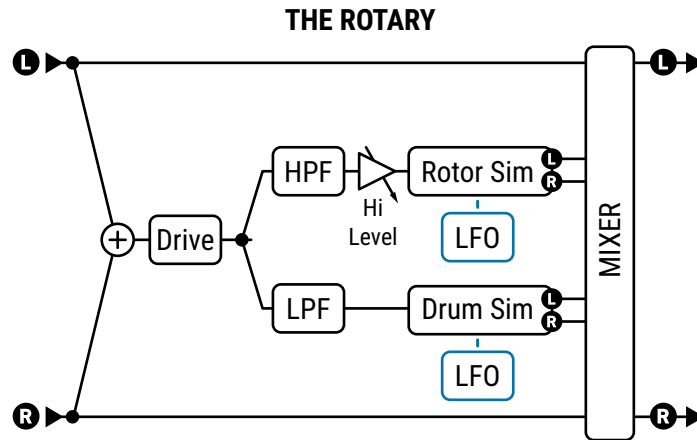

ROTARY PARAMETERS

Rate – Controls the spin rate for both the drum and rotor. Assign a modifier for real-time control. You can even set the rate to 0.0 to “park” the rotary. To make the drum spin more slowly, as it might in a real rotary, adjust **Low Rate Multiplier** (below). When shown in parenthesis, it is being controlled by the tempo (below).

Tempo – Locks the rate in rhythmic relation to the Tempo. Set to “NONE” for manual rate control.

Drive – Give your virtual rotary speaker the grit and grind of the classic with this overdrive control.

Hi Depth – Sets the modulation depth of the rotor. To simulate a drum-only cabinet, reduce this value fully.

Hi Level – Sets the output level of the rotor. Use this to balance the level between the drum and rotor.

Low Depth – Sets the modulation depth of the drum. Higher settings provide a more pronounced throb.

Rotor Length – Adjusts the length of the virtual high-frequency horn. Larger values increase the amount of Doppler shift and result in a more intense effect.

Low Rate Multiplier – Adjusts the speed of drum compared to the rotor.

Low Time Constant, Hi Time Constant – Sets acceleration/deceleration rates for the drum (low) and rotor (hi) so they realistically “spin up” or down when you change the Rate or Tempo.

LF Mic Spacing, HF Mic Spacing – These set the placement of the (neutral-sounding) virtual mics, determining the stereo width of the effect. Setting zero (default) simulates a mono mic on the drum.

Mic Distance – These set the distance of the virtual mics.

Stereo Spread – Controls stereo width by setting the pan position of the effect from hard-panned (100%) to dead mono (0%) – and beyond, with psychoacoustic effects increasing the apparent width from -200% to +200%. (You’d be surprised at how many rotary recordings are actually mono!)

The Rotary block also has **Mix, Level, Balance, Bypass**, and **Bypass Mode** parameters.

See [“Common Mix/Level Parameters” on p. 7.](#)

THE SCENE MIDI BLOCK

MIDI

The Scene MIDI block is unlike other blocks in that instead of processing audio, it transmits MIDI messages through the **MIDI OUT** port of the Axe-Fx or FM3. It is set up through a single page with no types or channels. It must be manually placed on the grid for per-Scene MIDI messages to be transmitted at all. It cannot be bypassed, but any scene can be set up to transmit no messages.

Once the Scene MIDI block has been placed on the grid, press **EDIT** to show its menu page.

- ▶ The **current Scene number** is shown at the top of the display.
- ▶ The eight table rows represent **eight different messages** that can be sent for the current scene.
- ▶ The four table columns are used to program MIDI messages. For each message, you can select:
 - **Type:** Determines whether the message will be a "PC" (Program Change) or a "CC" (Control Change).
 - **Channel:** Sets the MIDI Channel for the selected message.
 - **Number:** Sets the CC number, if the message is a Control Change.
 - **Value:** Sets the actual PC or CC message data.
- ▶ Beneath the table, buttons for **Scene Down (-)** and **Scene Up (+)** change the scene.
- ▶ The **Clear Row** button clears all parameter values for the current row in the current scene.
- ▶ The **Test Row** block allows you to transmit a single row for testing purposes.

Several examples of Scene MIDI block programming appear below. Unused commands are not shown.

EXAMPLE 1:

In this example, Scenes 1 and 2 each transmit two different PCs to devices on channels 3 and 4.

Scene: 1				
	TYPE	CHANNEL	NUMBER	VALUE
Command 1	PC	3	--	11
Command 2	PC	4	--	64

Scene: 2				
	TYPE	CHANNEL	NUMBER	VALUE
Command 1	PC	3	--	14
Command 2	PC	4	--	59

EXAMPLE 2:

In this example, Scenes 1 and 2 each transmit two different CCs to devices on channels 3 and 4. Imagining two toggle switches, the values swap from one scene to the next.

Scene: 1				
	TYPE	CHANNEL	NUMBER	VALUE
Command 1	CC	3	0	80
Command 2	CC	4	127	81

Scene: 2				
	TYPE	CHANNEL	NUMBER	VALUE
Command 1	CC	3	127	80
Command 2	CC	4	0	81

EXAMPLE 3:

In this example, Scenes 1 transmits a CC and a PC to a device on Channel 9. Scene 2 transmits nothing to the device on Channel 9, but sends different messages to three other devices.

Scene: 1				
	TYPE	CHANNEL	NUMBER	VALUE
Command 1	CC	9	0	1
Command 2	PC	9	--	21
Command 3	--	--	--	--

Scene: 2				
	TYPE	CHANNEL	NUMBER	VALUE
Command 1	PC	5	--	100
Command 2	PC	6	--	19
Command 3	CC	7	16	63

THE SEND BLOCK

SND

The Send block passes audio to the Return block (see below). On the grid, the Send block behaves exactly like a Shunt. It does not process audio and cannot be bypassed. It has no parameters.

THE RETURN BLOCK

RTN

The Return block receives audio from the Send block. Send and Return blocks must be used in pairs. There are two pairs of Send and Return blocks available. Receive 1 receives audio only from Send 1, while Receive 2 receives audio only from Send 2.

Send and Return blocks allow you to route signal from any point to any other point, bending the rule that signal must only flow from left to right. No connection will be visible between the two blocks, but signal will still flow from the output of the Send to the input of the Return. Both blocks must be used for either to function.

Send and Return blocks have two main uses: (1) creating feedback loops and (2) extending the length of effects chains beyond the size of the grid.

PARAMETERS

Return Level – Scales the level of the signal from the Send block that is passed to the grid by the Return block.



WARNING: Use these blocks with caution, as you can easily program an unstable loop and cause internal clipping and/or dangerously high sound levels. Begin with the Return Level at 0% and bring it up slowly. If you start to hear squealing or runaway feedback, immediately bring the value to minimum and analyze your routing for possible causes of instability.

Output Level – This adds an additional boost or cut to the signal received from the Send block.

This block has **Balance**, **Bypass**, and **Bypass Mode** parameters. See [“Common Mix/Level Parameters” on p. 7.](#)

FEEDBACK LOOPS

Feedback loops allow you to combine effects in interesting ways and then route the output back to the input. The figure below demonstrates this by using an overlay of a preset illustration rendered in Axe-Edit.

Signal enters the grid at (1), passes through the Amp and Cab blocks, and reaches the output (2), where it is heard in the speakers as you play. Meanwhile, a tap of this main line at (3) carries signal to a Graphic EQ, and a Delay set to 500 ms, with no feedback and mix at 100%. Because of the mix setting, nothing comes out of the delay for 500 ms. Then, the first echo is routed by a cable (4) to the output (2). This echo *simultaneously* enters the Send block (5) and is routed to the Return (6). From here it again passes through the GEQ—and hits the delay again. Each previous echo that cycles through has one extra pass of any other effects in the loop. The purple dotted line shows the imagined path that signal takes between Send and Return.

This feedback loop of **GEQ ▶ Delay ▶ Send ▶ Return** would continue forever if the **Return Level** parameter didn't make it a bit quieter each time so that it eventually fades away.

So to review, the **Send** "transports" signal to the **Return**, where **Return Level** controls the amount of feedback.

Countless variations of Send/Return loop presets are possible when you use different effects, vary their order, or enter and tap the loop in different places.

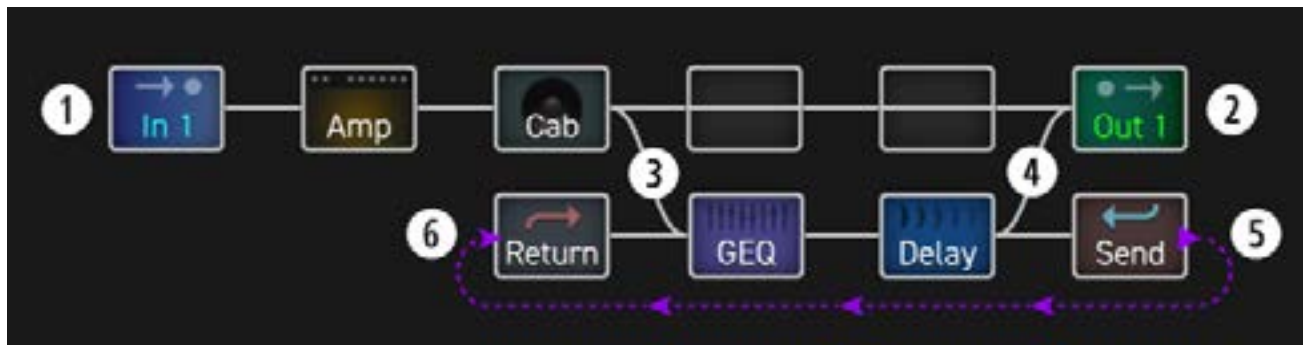

EXTENDED LAYOUTS

The 14x6 grid will suffice for the vast majority of long, complex routings. However, sometimes the "need to exceed" means building an effects chain that is longer than the number of columns available in the grid. The Send and Return blocks can be used for exactly this purpose. Place a Send block at the end of your first chain and place a Return block at the beginning of another, setting Return Level to "100%". Continue through other effects to an output as illustrated below. By the way, this real preset with 28 blocks hits just over 80% CPU usage!



THE SYNTH BLOCK

SYN

The Synth block is a 3-oscillator monophonic synthesizer that can be used for a fantastic range of monophonic guitar synth sounds, special effects, and as a tone generator for testing purposes.

A monophonic synthesizer tracks single note playing.

Modifiers and controllers may be used to affect a variety of synth functions for real time effects.

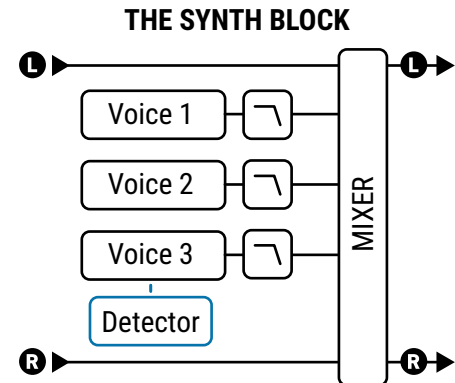

SYNTH PARAMETERS

Each of the three synth voices has its own oscillator and filter with the following parameters:

Type – Sets the oscillator waveform to Sine, Triangle, Square, Sawtooth, Random, White Noise, Pink Noise, or OFF. (Setting a synth voice to “OFF” helps conserve CPU).

Track – Selects the type of input tracking.

- **OFF** – Allows the frequency and level to be set manually via the FREQ and LEVEL controls.
- **ENV ONLY** – Selects the level to be controlled by the envelope while frequency is set manually.
- **PITCH+ENV** – Selects the frequency and level to be controlled by the pitch and envelope of the input.

Frequency – If input tracking is set to “OFF” or “ENV ONLY,” this parameter sets the oscillator frequency.

Shift – Shifts the frequency of the oscillator up or down in semitone steps.

Tune – Detunes the oscillator slightly. The oscillator can be detuned +/- 50 cents.

Duty Cycle – When using the TRIANGLE or SQUARE waveforms, this parameter controls the symmetry or pulse width of the waveform.

Pan – Controls the panning of the oscillator.

Filter Frequency – Sets the cutoff frequency of a low-pass filter after the oscillator.

Filter Q – Sets the Q or resonance of the post-oscillator filter.

Attack – Sets the attack time of the envelope follower on the input.

Level – Each voice also has its own level control, located on the Mix page.

The Synth block also has **Mix**, **Level**, **Balance**, **Bypass**, **Bypass Mode** and **Global Mix** parameters.

See [“Common Mix/Level Parameters” on p. 7.](#)

THE TEN-TAP DELAY

TTD

The Ten-Tap Delay is fairly self-explanatory, but has a number of features which allow it to be used for some very creative effects. Echoes sweep across the stereo field or play in unique rhythms with this exciting block.

TYPE PAGE

Type – Select a type using the **VALUE** or **NAV** buttons with no need to press **ENTER**.

- **Ten-Tap Delay** – The Ten-Tap Delay provides a unique way to control the time, pan, and spacing of one to ten separate echoes. Instead of feedback, it uses an innovative **Decay** control to determine how the level of the ten taps changes over time. The levels of individual delay taps can also be adjusted from -80 to +20 dB. Pan is set as a **Shape** that can change automatically as the taps progress.
- **Rhythm Tap Delay** – The Rhythm Tap Delay uses the same algorithm as the Ten-Tap Delay but allows you to create a custom rhythm of repeats. You can enter the rhythm in three ways:
 1. By specifying the number of milliseconds between each tap and the previous one.
 2. By specifying some number of quantized time units (“divs”) between each tap and the previous one.
 3. By using the **LEARN** function to tap a rhythm with the **ENTER** button.

CONFIG PAGE

Ten-Tap Delay and Common Parameters

Mono/Stereo – Sets the mode of the Ten-Tap Delay. In mono mode, twice as much delay per tap is possible.

Delay Time – Sets the time between delay taps. When shown in parentheses, it is being set automatically by **Delay Tempo** (below). Set **Delay Tempo** (below) to “NONE” for manual control.

Delay Tempo – Sets the Delay Time in rhythmic relation to the Tempo.

Number Of Taps – Sets the exact number of repeats.

Decay – Sets how rapidly the volumes of the repeats decay over time. Remember that each tap also has an individual **Level** control which can be instead of **Decay** – or alongside it – to create custom patterns of level. The following diagram illustrates the effect of decay. The first bold line is the original signal.

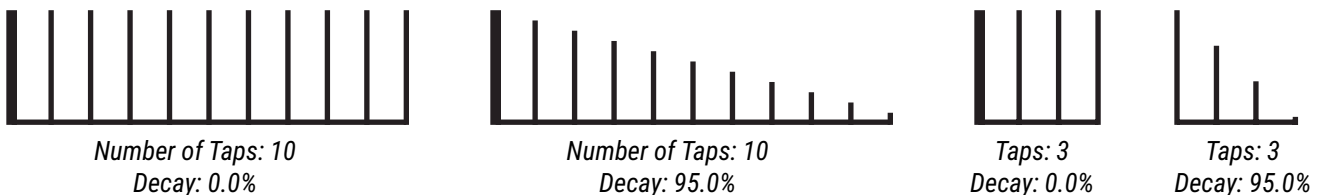

Shuffle – Sets the amount of time-offset for the odd-numbered taps to give a shuffle feel to the repeats.

Spread – In Stereo mode, this sets the spread of the repeats. At maximum, the left channel is panned fully left and the right channel fully right.

Ratio – In Stereo mode, adjusts the left time as a percentage of the right.

Pan Shape – Controls the shape of the panning as a function of the tap number. The repeats can move slowly from one side to the other (“increasing” or “decreasing”), stay “constant,” or move back and forth (“sine”).

Pan Alpha – Controls how quickly the repeats move as a function of tap number and pan shape. Higher values produce a more pronounced effect. To alternate left-to-right, set Shape to “SINE” and Pan Alpha to maximum.

Low Cut, High Cut – These set the cutoff frequencies of high- and lowpass filters to adjust effect tone.

Tap Level 1-10 – Adjusts the relative level of the selected tap from -80 to +20 dB.

Rhythm Tap Delay Parameters

The parameters of the Rhythm Tap delay include those of the Ten-Tap delay except Delay Time/Tempo and Shuffle. It has the following additional parameters for creating unique rhythmic echo patterns:

Feedback – Sets the feedback level from the final repeat to the input of the delay line. This is just like feedback in a regular Delay block, except instead of determining how many times a single echo will repeat, this is how much the entire pattern will repeat.

Quantize – Changes **Tap Time** units (see below) from milliseconds to rhythmic subdivisions, or “Divs”. The value of Quantize is the length of each div.

Learn – Use this function to enter a rhythm by tapping the **ENTER** button.

1. **NAV** to the **Learn** parameter.
2. Change the value of **Learn** to “TAP ENTER”.
3. Tap the rhythm you want using the **ENTER** button. Your first tap represents the original (dry) signal.
4. If **Quantize** is “NONE”, tap times will be set in milliseconds. Otherwise, each tap will be rounded to the nearest rhythmic subdivision. With Quantize turned ON, it is helpful if you use a metronome to guide you.
5. When finished tapping, change the value of **Learn** to “DONE”.

Tap Time 1–10 – These ten parameters sets the time of each tap relative to the one before it. Times are set in milliseconds or divisions (“divs”). The length of each div is whatever value you set for **Quantize** (and re-calculated based on the Tempo). For example, if Quantize is set to “1/16”, each div is 1/16th note, and all tap times will sound some whole number of 16ths after the preceding tap. If Quantize is “OFF”, you can enter millisecond values directly or use the Learn feature (above). Times that have been learned may be further adjusted manually.

MIX PAGE

This block has **Mix**, **Level**, **Balance**, **Bypass**, **Bypass Mode**, **Input Gain** and **Global Mix** parameters. See [“Common Mix/Level Parameters” on p. 7.](#)

THE TONE MATCH BLOCK

Axe-Fx III Only

TMA

The Tone Match block, offered only on the Axe-Fx III, changes the sound of a preset to match a reference signal, such as a recording or the feed from a mic on a live amp. The result can be saved into a preset, or exported as a User Cab for use in other presets. This block is detailed in a separate “Tone Match Mini Manual” available at:

<https://www.fractalaudio.com/downloads/manuals/axe-fx-3/Axe-Fx-III-Tone-Match-Manual.pdf>

THE TREMOLO/PANNER BLOCK

TRM

As its name suggests, the Tremolo/Panner block has two uses. A **tremolo** effect turns the overall volume up and down in a pulsing rhythmic way. You can hear tremolo sounds on *Gimme Shelter* by the Rolling Stones, *Boulevard of Broken Dreams* by Green Day and at the end of *Rumble* by Link Wray. Like a tremolo, a **panner** also varies volume, but when the left and right channels are changed in opposite directions, the “auto-pan” effect creates the illusion of motion in the stereo field. Panning covers anything from slow subtle swings to psychotic gyrations. Countless recordings use pan controls at the console to create dimensional stereo effects. Listen (in headphones, even) to *EXP on Axis: Bold as Love* by Jimi Hendrix, the middle section of *Whole Lotta Love* by Led Zeppelin, or the guitar solo in *Owner of a Lonely Heart* by Yes.

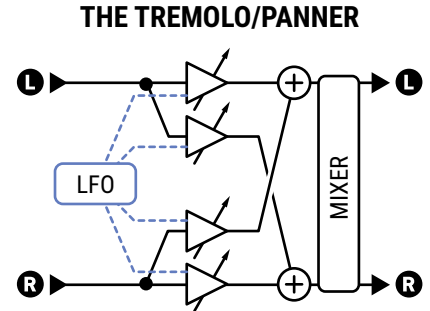

TREMOLO/PANNER PARAMETERS

Type – Chooses between **Tremolo**, **Panner**, **Bias Trem**, **Harmonic Trem** and **Optical Trem** effects.

Tremolo is a simple volume-based effect. The **Bias Trem** type creates a particularly organic sound evocative of tube bias tremolo circuits. The **Harmonic Trem** type recreates the famed sound of the tremolo circuit found in old “Brownface” amplifiers. This effect splits the spectrum and applies modulation to the two frequency bands. *Note: Bias Trem and Harmonic Trem may add distortion just as their tube-based counterparts would.*

Rate – Sets the frequency of the LFO that controls the effect. When shown in parentheses, rate is being set automatically by the **Tempo** parameter (see below). Set Tempo to “NONE” for manual control. Set fully counterclockwise to sync to the **LFO1** controller source (see your **Owner’s Manual**).

Tempo – Synchronizes the rate of the LFO in rhythmic relation to the Tempo. For example, if the Tempo is 120 BPM, and Tempo is set to a “1/4,” the LFO rate will be 2 Hz (120 BPM / 60 seconds = 2).

Depth/Width – Sets the depth of the LFO that controls the effect. Set higher for more dramatic effects. In the panner type, when **Width** is set to values above 100%, psychoacoustic effects create the illusion of panning beyond the boundaries of the normal stereo image.

LFO Type, LFO Duty Cycle – These sets the shape and contour or symmetry of the modulation waveform.

LFO Phase – Adjusts the phase difference between the left and right LFO waveforms. Use 0° for a true Tremolo, or 180° for perfect panning.

Start Phase – (Tremolo only) This allows you to force the effect to start from a fixed point in its cycle when you engage the effect. (TIP: Set it to 360 and work backwards until you hear the effect you’re after).

Trigger Threshold - Use this to keep tremolo in sync with your playing. Set the threshold so the tremolo cycle starts over whenever you begin playing. Set to OFF for a free-running LFO. Adjust Start Phase (above) to have the cycle begin exactly where you want it.

Crossover Slope, Crossover Frequency – These control the filter used by the harmonic trem.

Pan Center – (Panner only) this shifts the apparent center of the stereo image.

MIX PAGE

The Tremolo/Panner block has **Level**, **Balance**, **Bypass**, and **Bypass Mode** parameters. See [“Common Mix/Level Parameters” on p. 7.](#)

THE VOCODER BLOCK

Axe-Fx III Only **VOC**

The vocoder, created by Homer Dudley, was originally designed as means of compressing human speech for transmission over narrow-band carrier channels. In the 1970s, Robert Moog and Wendy Carlos pioneered the use of the vocoder for musical applications. This block pays faithful homage to those early analog vocoders with up to 24 bands and a “constant-Q” approach. It can make your guitar “talk” but can also be used with the Synth block to create robot voices and other effects.

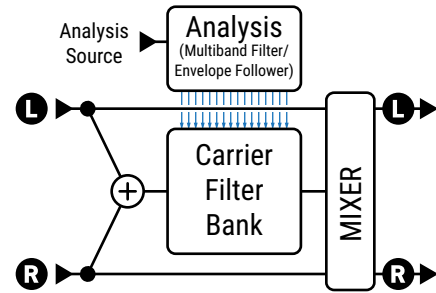

When using the vocoder with your guitar or another instrument, resist the urge to sing. Speaking in a clear monotone voice yields the best results.

VOCODER PARAMETERS

Analysis Source – This selects the input to provide the analysis or modulator signal. This is typically used for vocal input, while the “carrier” or “synthesis” signal is derived from the block’s input on the grid.

Analysis Channel – This selects whether the left or right channel is used for analysis.

Number Of Bands – Selects the number of bands to use in the analysis and synthesis filter banks.

Min Frequency – Sets the frequency of the lowest filter band.

Max Frequency – Sets the frequency of the highest filter band.

Filter Resonance – Sets the Q, or bandwidth, of the filters. Higher values yield narrower filters.

Frequency Shift – Shifts the frequency of the carrier/synthesis bands relative to the analysis bands. This allows you to change the character of the vocoding to produce “anonymous mob informant” or “chipmunk” effects.

Freeze – This locks the output of the envelope followers to hold the vocal formant.

Highpass Mix – This sets the amount of high-pass filtered signal to mix in with the output. This can be used to increase the intelligibility of the vocoding by allowing certain consonants and air sounds to pass right through.

Attack – Sets attack filter time for the envelope followers.

Decay – Sets release filter time for the envelope followers.

Master Level – Sets the master level for all the synthesis filter outputs.

Master Pan – Sets master panning for all the synthesis filter outputs. Individual control of the filter output levels and panning is provided on dedicated menu pages. You can use these controls to fine-tune the filter bank response and control the panning of the filter outputs.

Level 1–24 – These set the out level for each of the 16 bands.

Pan 1–24 – These set the out pan for each of the 16 bands.

MIX PAGE

This block has **Mix, Level, Balance, Bypass, Bypass Mode, Input Gain** and **Global Mix** parameters. See [“Common Mix/Level Parameters” on p. 7.](#)

THE VOLUME/PAN BLOCK

VOL

The Volume/Pan block can be used as a dynamic control with an external expression pedal, but is also very useful as a static boost or cut, to mute the signal, pan, or isolate left/right channels.

Type – Selects between a simple volume control and “Auto-Swell” based on the rare vintage “slow gear” effect, which replicates the sound of a guitarist rolling their volume knob up before the attack of each note.

Volume – Scales the output level out of the block. Assign a modifier to create a volume pedal.

Threshold and **Attack** – Use these to set the threshold and volume “roll up” speed when the type is “Auto-Swell”

Balance – Sets the balance (L/R) out of the block.

Taper – Sets the “taper” of the volume control. “LINEAR” selects a linear taper. Log 30A, 20A, 15A, 10A and 5A select various types of potentiometer typically used for volume control.

Input Select – This control determines how incoming stereo signals will be passed. Options include STEREO, LEFT ONLY, or RIGHT ONLY.

Pan Left, Pan Right – Controls the panning of the left and right output signals.

Bypass Mode – Determines whether input signals should pass through or be muted when this block is bypassed.

Level – Sets the output level of the block independent of the setting for the **Volume** control.

THE WAHWAH BLOCK

WAH

Country guitar virtuoso Chet Atkins created his own Wah-wah pedal in the late 1950s but the effect really took off after Clapton used it on *Tales of Brave Ulysses* with Cream in 1967. From Jimi Hendrix's *Voodoo Chile* to, well, Stevie Ray Vaughan's *Voodoo Chile*—and right up to the present— the wah pedal, with its onomatopoeic name, remains one of the most cherished and recognizable guitar effect sounds of all time.

The Wah block is the embodiment of this great legacy but with modern reliability and control and a smooth feel without the problems that can plague the electromechanical version. Place a wah before distortion for a classic sound or after distortion for more of a synth-like sound. The effect is stereo-in/stereo-out.

PARAMETERS

Type – Selects between different wah types based on classic vintage and cutting edge modern designs.

Type	Based On
FAS Wah	A custom Bandpass wah by Fractal Audio Systems.
Clyde	Based on an original Vox Clyde McCoy wah.
Cry Babe	Based on a Dunlop Cry Baby.
VX846	Based on a Vox V846-HW hand-wired wah.
Color-Tone	Based on a Colorsound wah.
Funk Wah	Modeled after the “Shaft” sound.
Mortal	Based on a Morley wah/volume pedal.
VX845	Based on a Vox V845.

Wah Control – Sets the position of the wah. Normally you would assign this parameter to a pedal for real-time control, but you can also set it to an LFO or “park” it manually (so you can play the guitar on the MTV).

Control Taper – Defines the sweep or feel of the wah with selections representing various potentiometer tapers.

Resonance Q – Sets the resonance (“Q”) of the filter. Higher values give a more pronounced response.

Q Tracking – Some classic wah pedals become less resonant as you push the pedal down. This control mimics that effect, so that as frequency is increased, the resonance decreases, becoming less “peaky” and harsh.

Low Cut Frequency – Applies a highpass filter, as created by the internal coupling capacitor of a real wah pedal.

Minimum Frequency – Sets the frequency of the filter when the frequency control is at its lowest value. This can be adjusted to match the range of your instrument or preference.

Maximum Frequency – Sets the frequency of the filter when the frequency control is at its highest value.

Drive – This simulates overdriving the circuit of the wah pedal.

Inductor Bias – This adjusts the DC offset of the virtual inductor which interacts with the **Drive** parameter to replicate the subtle (and awesome) sound of some of the most coveted wah pedals.

Fat – This is actually a mix control, adding dry signal to the wah for up to 50/50 wet/dry mix.

EQ PAGE

A built-in 8-band, 2/3 octave Graphic EQ can be enabled/disabled via the **EQ ON/OFF** parameter on the Mix page.

MIX PAGE

The Wah block has **Level**, **Balance**, **Bypass**, and **Bypass Mode** parameters. See [“Common Mix/Level Parameters” on p. 7.](#)

LFO WAVEFORMS & PHASE

All of the modulation effects (chorus, flanger, delays, phaser, tremolo, etc.) and the two global LFOs, share a common set of waveform types—“shapes” that define the way values change over time. These are represented below, together with an indication of how the **Duty** parameter controls wave symmetry.

Remember that in cases where an LFO modulates the delay time (chorus, flanger, and any delay blocks) it is the slope, rather than the actual LFO “value,” that determines the pitch offset at any moment. A triangle with a constant up/down slope will “sound” like the square wave “looks.” A square wave with no effective slope will produce only a series of clicks unless used with some “damping”.

Type	50% Duty Cycle (Normal)	0% Duty	100% Duty
Sinev		NA	NA
Triangle			
Square			
Saw Up		NA	NA
Saw Down		NA	NA
Random		NA	NA
Log		NA	NA
Exponential (Exp)		NA	NA
Trapezoid			
Astable			

The Astable waveform does not use the “Duty” control. Instead it has its own “Astable Beta” parameter which transforms the shape as shown here at low and high values.

LFO PHASE

Phase adjustments shift the alignment of the “RIGHT” or “B” LFO output. At 0° (below, far left), the two channels are in phase; at 180° (below, far right), the two signals are phase-opposite, so while one is swinging from 0 to 1, the other is swinging from 1 to 0 (and vice versa). Any interim setting is also allowed.

Phase has no effect on the RANDOM waveform.

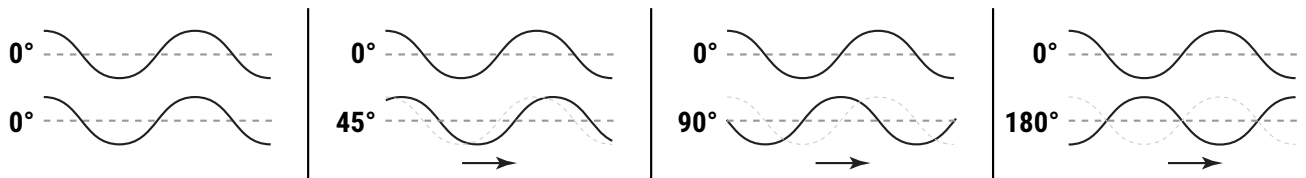

TEMPO CROSS REFERENCE

The tables below list the rhythmic values available in every Tempo parameter on the Axe-Fx or FM3. The first lists these in the order they appear as you scroll through the Tempo list, with their equivalent in Beats.

The second table (cross-referenced to the first by the INDEX) lists tempo time values from shortest to longest.

Values in Actual Order, with Beat Equivalents

INDEX	VALUE	BEATS	INDEX	VALUE	BEATS
1	1/64 trip	0.042	40	22/64 (11/32)	1.375
2	1/64	0.063	41	23/64	1.438
3	1/64 dot	0.094	42	25/64	1.563
4	1/32 trip	0.083	43	26/64 (13/32)	1.625
5	1/32	0.125	44	27/64	1.688
6	1/32 dot	0.188	45	28/64 (7/16)	1.75
7	1/16 trip	0.167	46	29/64	1.813
8	1/16	0.25	47	30/64 (15/32)	1.875
9	1/16 dot	0.375	48	31/64	1.938
10	1/8 trip	0.333	49	33/64	2.063
11	1/8	0.5	50	34/64 (17/32)	2.125
12	1/8 dot	0.75	51	35/64	2.188
13	1/4 trip	0.667	52	36/64 (9/16)	2.250
14	1/4	1	53	37/64	2.313
15	1/4 dot	1.5	54	38/64 (19/32)	2.375
16	1/2 trip	1.333	55	39/64	2.438
17	1/2	2	56	40/64 (5/8)	2.5
18	1/2 dot	3	57	41/64	2.563
19	1 trip	2.667	58	42/64 (21/32)	2.625
20	1	4	59	43/64	2.688
21	1 dot	6	60	44/64 (11/16)	2.75
22	2	8	61	45/64	2.813
23	3	12	62	46/64 (23/32)	2.875
24	4	16	63	47/64	2.938
25	4/3	5.333	64	49/64 (49/64)	3.063
26	5/4	5	65	50/64 (25/32)	3.125
27	5/64	0.313	66	51/64	3.188
28	7/64	0.438	67	52/64 (13/16)	3.25
29	9/64	0.563	68	53/64	3.313
30	10/64 (5/32)	0.625	69	54/64 (27/32)	3.375
31	11/64	0.688	70	55/64	3.438
32	13/64	0.813	71	56/64 (7/8)	3.5
33	14/64 (7/32)	0.875	72	57/64	3.563
34	15/64	0.938	73	58/64 (29/32)	3.625
35	17/64	1.063	74	59/64	3.688
36	18/64 (9/32)	1.125	75	60/64 (15/16)	3.75
37	19/64	1.188	76	61/64	3.813
38	20/64 (5/16)	1.25	77	62/64 (31/32)	3.875
39	21/64	1.313	78	63/64	3.938

Values from Shortest to Longest

VALUE	AKA	INDEX	VALUE	AKA	INDEX
1/64 trip	1/96th	1	33/64		49
1/64		2	34/64 (17/32)		50
1/32 trip	1/48th	4	35/64		51
1/64 dot		3	36/64 (9/16)		52
1/32		5	37/64		53
1/16 trip	1/24th	7	38/64 (19/32)		54
1/32 dot	3/64th	6	39/64		55
1/16		8	40/64 (5/8)		56
5/64		27	41/64		57
1/8 trip	1/12th	10	42/64 (21/32)		58
1/16 dot	3/32nd	9	1 trip	2/3	19
7/64		28	43/64		59
1/8th		11	44/64 (11/16)		60
9/64		29	45/64		61
10/64 (5/32)		30	46/64 (23/32)		62
1/4 trip	1/6th	13	47/64		63
11/64		31	1/2 dot	3/4	18
1/8 dot	3/16th	12	49/64 (49/64)		64
13/64		32	50/64 (25/32)		65
14/64 (7/32)		33	51/64		66
15/64		34	52/64 (13/16)		67
1/4		14	53/64		68
17/64		35	54/64 (27/32)		69
18/64 (9/32)		36	55/64		70
19/64		37	56/64 (7/8)		71
20/64 (5/16)		38	57/64		72
21/64		39	58/64 (29/32)		73
1/2 trip	1/3rd	16	59/64		74
22/64 (11/32)		40	60/64 (15/16)		75
23/64		41	61/64		76
1/4 dot	3/8th	15	62/64 (31/32)		77
25/64		42	63/64		78
26/64 (13/32)		43	1	whole	20
27/64		44	5/4		26
28/64 (7/16)		45	4/3		25
29/64		46	1 dot	3/2	21
30/64 (15/32)		47	2	2 bars	22
31/64		48	3	3 bars	23
1/2		17	4	4 bars	24

GETTING HELP

Our forum is a source of great help ranging from product Q&A to tutorials and more. Fractal Audio staff participate in the conversations, and response times can be very fast.

Find it at <https://forum.fractalaudio.com>

A wiki maintained by members of the Fractal Audio community, is also an excellent resource:

<https://wiki.fractalaudio.com>

You can get support directly from Fractal Audio Systems at: <https://support.fractalaudio.com>
or internationally via our dealers listed at <https://www.fractalaudio.com/international-ordering>